

Loom

Métier



3310-0000

**IMPROVED!
JANUARY 2000**

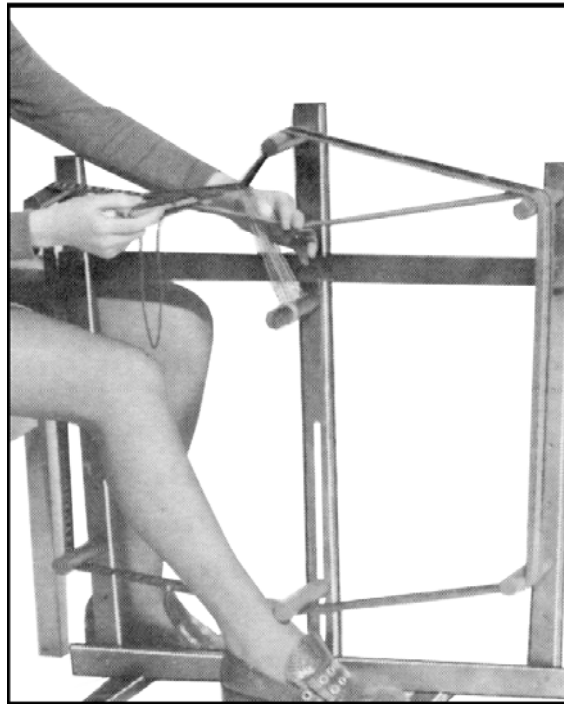

Leclerc Looms



Since 1876

1573 Savoie
C. P. 4
Plessisville, Qc.
G6L 2Y6

TEL: 819-362-2408
FAX: 819-362-2045

info@leclerclooms.com
www.leclerclooms.com

PARTS LIST

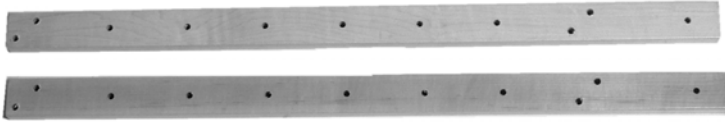

2 Vertical Boards 28" x 3/4" x 1 1/2"



1 Central Vertical Board
31" x 3/4" x 1 1/2"



1 Top Cross Member (Leclerc
Logo) 28" x 3/4" x 1 1/2"



1 bottom Cross Member
28" x 1 1/4" x 1 1/2"

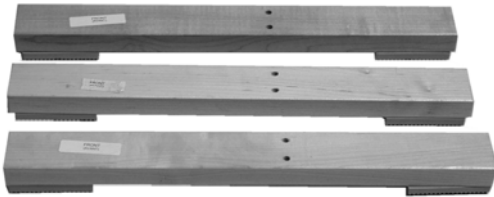

3 Base Boards 14" x 3/4" x 1 1/2"

Note for Leclerc in French:
Coller étiquette (avant) sur 4
pièces.



1 Peg with slot
4" x 7/8"



18 Pegs
1" x 6 5/16"

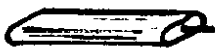

1 Flat Peg
3/4" x 1 1/2" x 7 3/8"



6 Carriage Bolts
2 1/2" x 1/4"



6 Carriage Bolts
2" x 1/4"



12 Auto-lock Nuts 1/4"

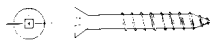

6 Flat Head Screws
#8, 1 1/4"



20 Wing nuts 1/4"



32 Washers 1/4"



1 Flat Shuttle 6"
1 Flat Shuttle 10"



1 Screwdriver (red)
1 tournevis (#2 rouge)

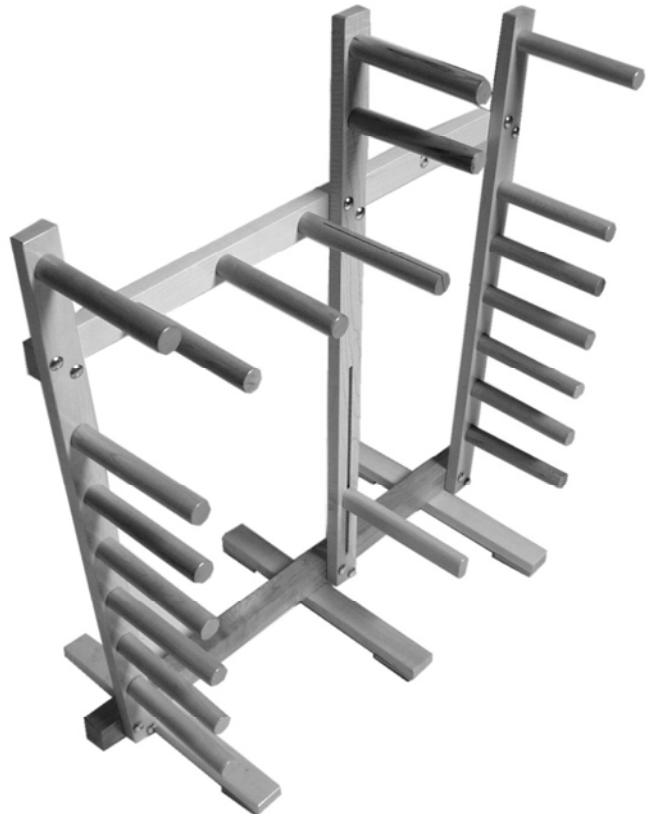

Assemble the Bottom Cross Member with the 3 Base Boards. Small pre-drilled holes are made in the bottom cross member. The longer part of the base boards goes in the front. Use the 6 flat head screws #8, 1 1/4"

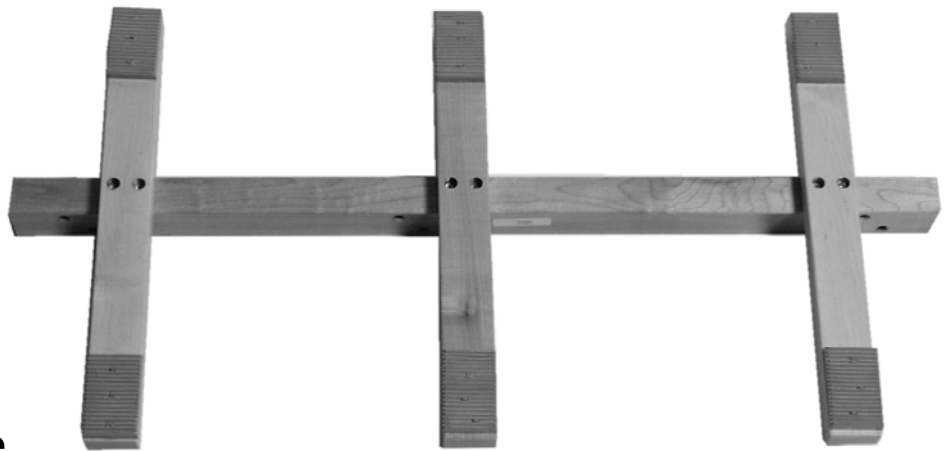

ATTENTION: Application of soap to the screws will make their insertion easier.

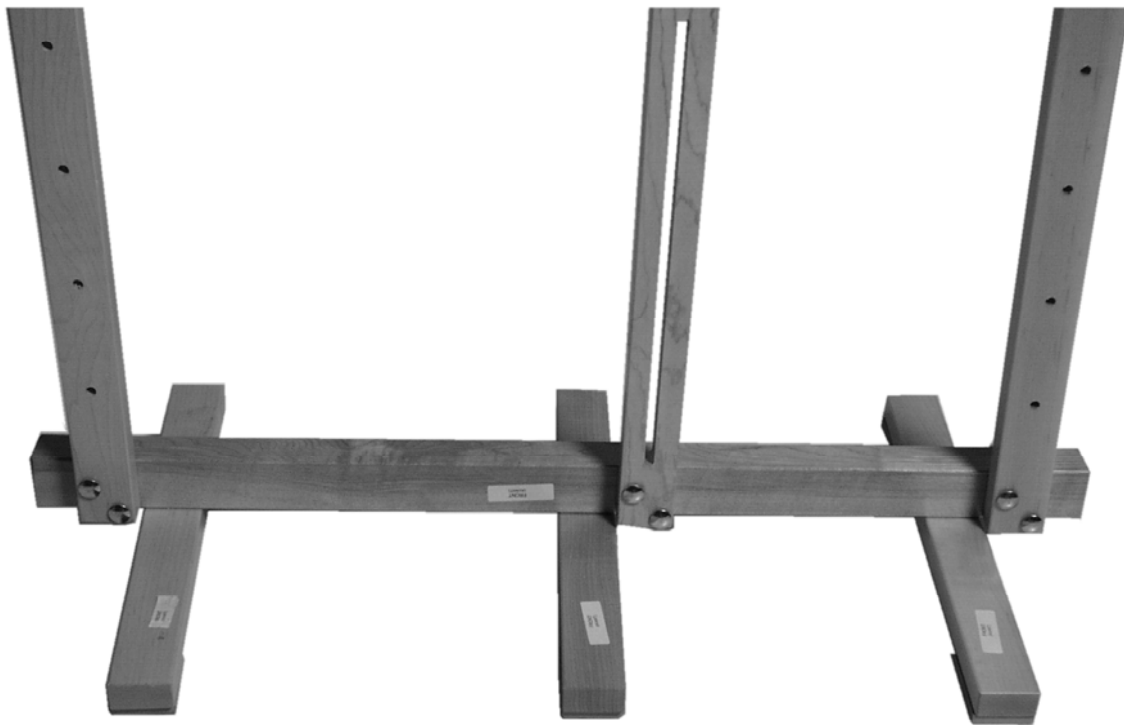

Affix the Vertical Boards and the Central Vertical Board as shown here using the 6 carriage bolts 2 1/4" x 1/4"
Hammer the carriage bolt in it will lock while you will screw in the nuts.
Do not completely tighten the nuts yet.

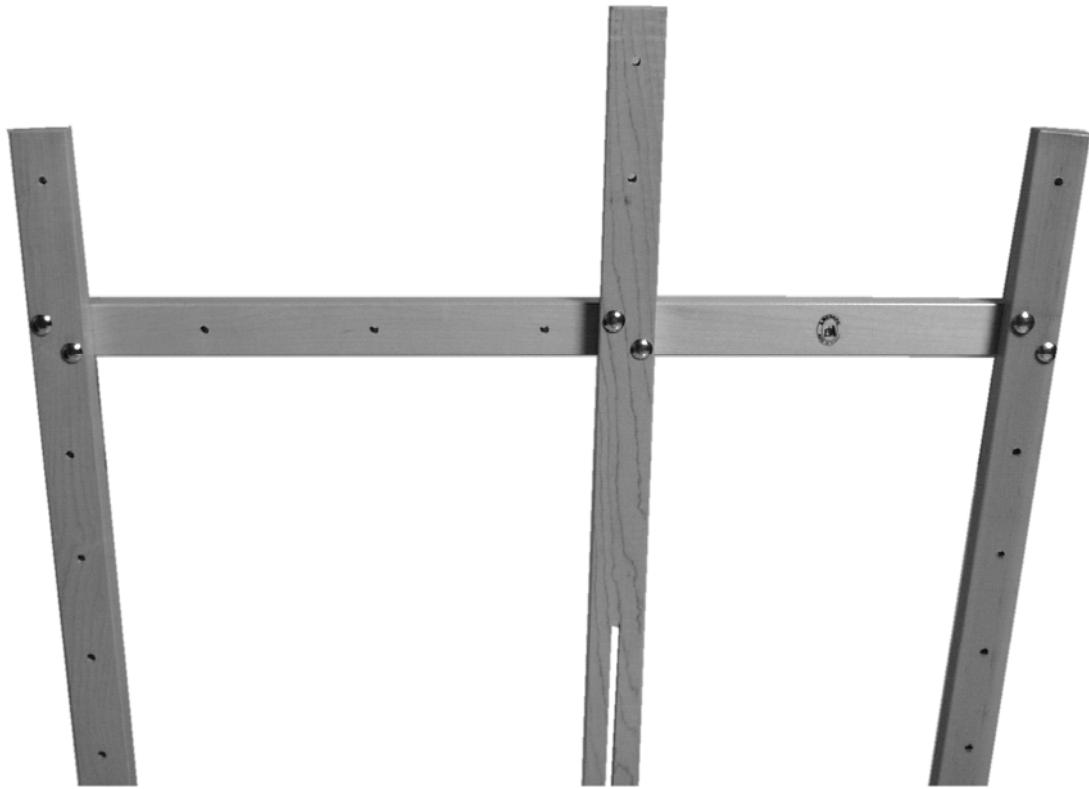

Affix the Top Board as shown here using the 6 carriage bolts 1 $\frac{3}{4}$ " x $\frac{1}{4}$ "
Hammer the carriage bolt in it will lock while you will screw in the nuts.
You can now tighten all carriage bolts.

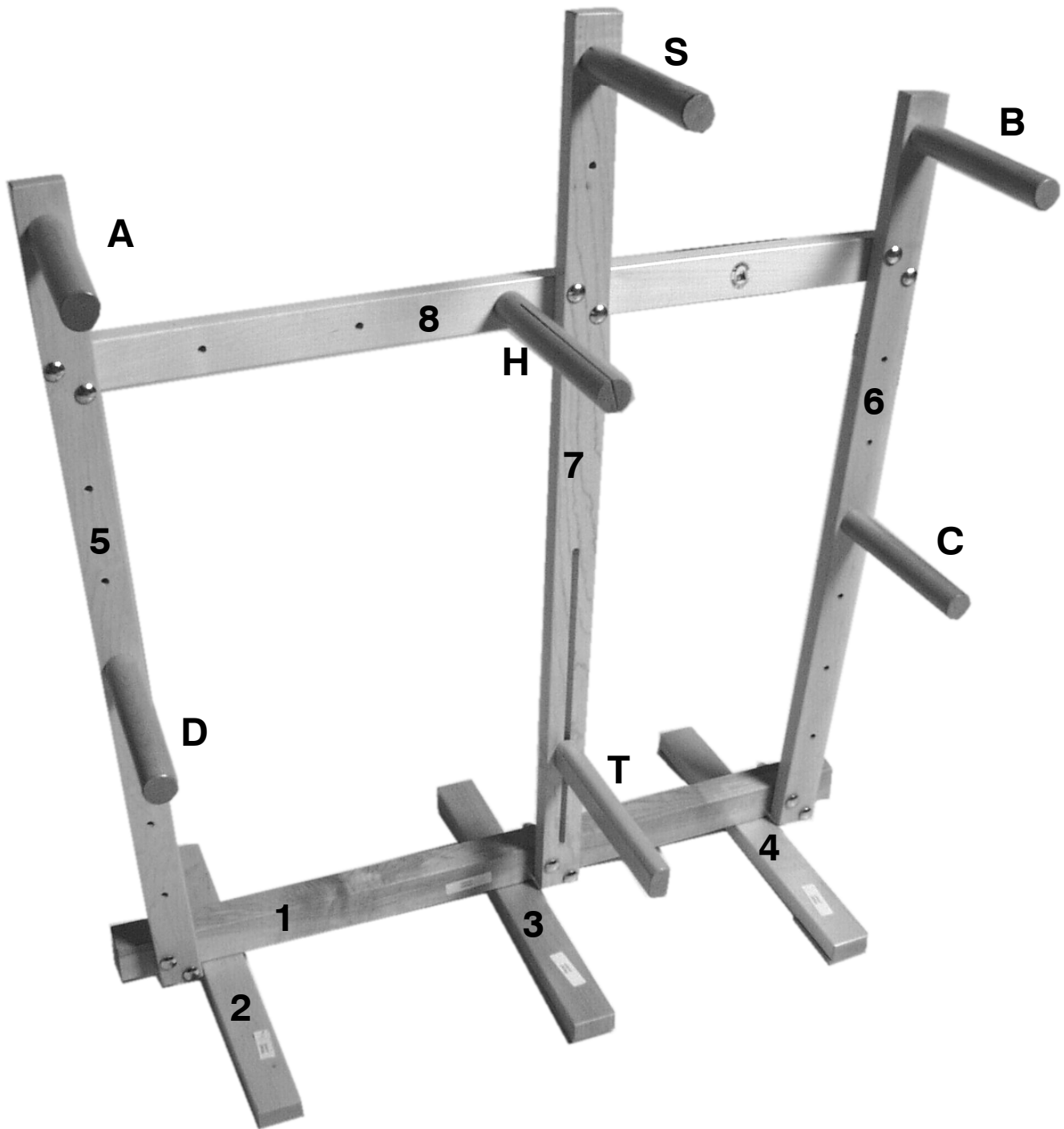

All pegs must be screwed firmly using the washers and wing nuts so they will not move.

The front (5) and back (6) upright members each have a top peg that is fixed in position, and each have a lower peg that can be moved to adjust the length of the warp being made on the loom.

The central upright (7) has two pegs, an upper stretcher peg S, and a lower tension peg T. The upper cross member (8) has a slotted peg H (heddle peg). The S peg is solid, and is fixed in position. H is also fixed in position, but has a slot to hold loops made of strong twine, called heddles. T can be moved up or down in a vertical slot in the upright, allowing take-up or let off of tension on the warp as required.

For making heddles or using loom as warping frame, pegs G and J are added.

WEAVING ON AN INKLE LOOM

An "inkle" is a narrow woven band, and an inkle loom is a simple loom designed for weaving narrow but strong strips of fabric.

This type of fabric is both useful and ornamental, and throughout the inkle loom's long history various forms of this simple loom have developed in widely separated times and cultures. The Leclerc open- side "Cendrel" is a most efficient and versatile form of inkle loom.

As well as being a loom, the "Cendrel" can be converted to a warping frame. Thus this beginner's loom becomes an efficient basic tool for the advanced weaver as well.

The inkle loom presents the novice weaver with an approach to weaving that is simple, practical and artistic. While the imagination of the new weaver is often fresh and original, technical control is usually limited and of fairly short duration. Warping this loom is quick, and so simple that a child can learn the technique easily. The weaving itself is swift and silent, and attractive, colorful articles can be completed in an hour's time. This floor model loom provides easy, quiet enjoyment for people of any age. Wound with a brightly colored warp, the "Cendrel" makes an attractive decoration.

Uses of the "Cendrel" are as varied as the people who weave with it; belts, neckties, headbands, guitar straps are but a few. Bands as wide as six inches can be woven, making it possible to produce large articles by joining woven strips together to achieve any width desired.

Thus purses; cushions, wall hangings, table runners and mats, mats for hot dishes, ponchos., vests, and a host of other articles, limited only by the imagination of the weaver, can be made.

There are four simple steps to be mastered.

First, the yarns must be warped onto the loom with an even tension. Second, the warp yarns must be separated into two alternating positions called sheds. Third, a continuous yarn carried on a shuttle, called the weft yarn, must be carried through the sheds at a right-angle to the warp and beaten into place. Fourth, as the warp shortens in the process of weaving because of take-up, tension must be released to allow the warp to move forward.



Purse illustrated above can be entirely made on a Cendrel as it is in bands of four inches wide and then sewn together. The variation in drawing has been made with a pick-up stick.

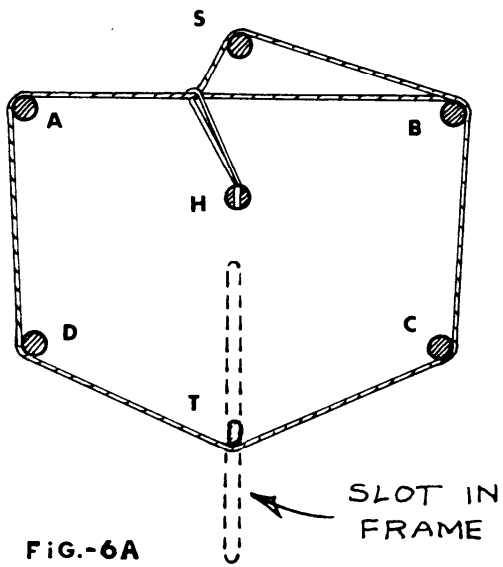

FIG.-6A

SHORT WARPS

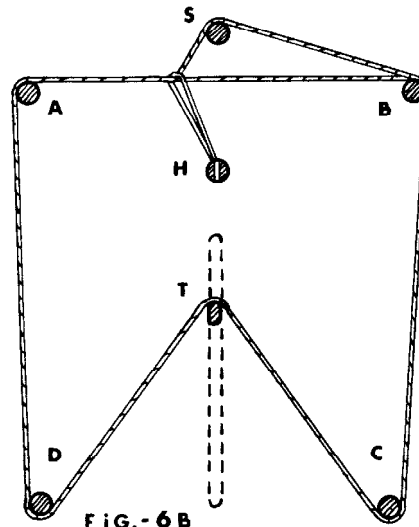

FIG.-6B

MEDIUM WARPS

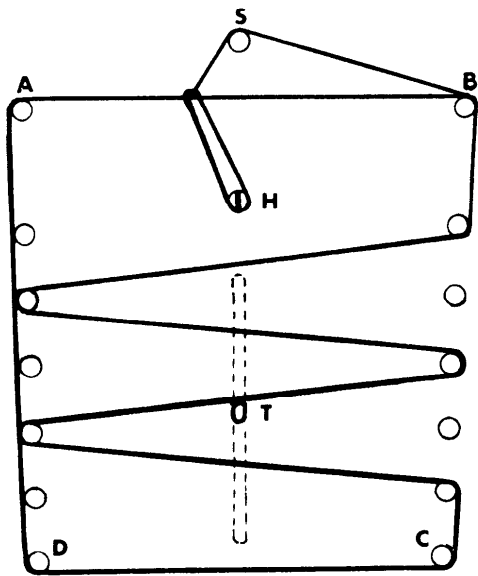

FIG.-6C

LONG WARPS

The tension peg T is set in the center of the vertical slot before warping is started. Tension can be taken up as required when weaving begins, and can be let off as the weaving proceeds. For a short warp, pass the yarn below the tension peg. (Fig. 6-A)

For a medium warp, pass the warp above the tension peg. (Fig. 6-B)

For a longer warp add as many pegs as needed and pass the warp around the pegs (Fig. 6-C)

There are two methods of making heddles and placing them on the loom.

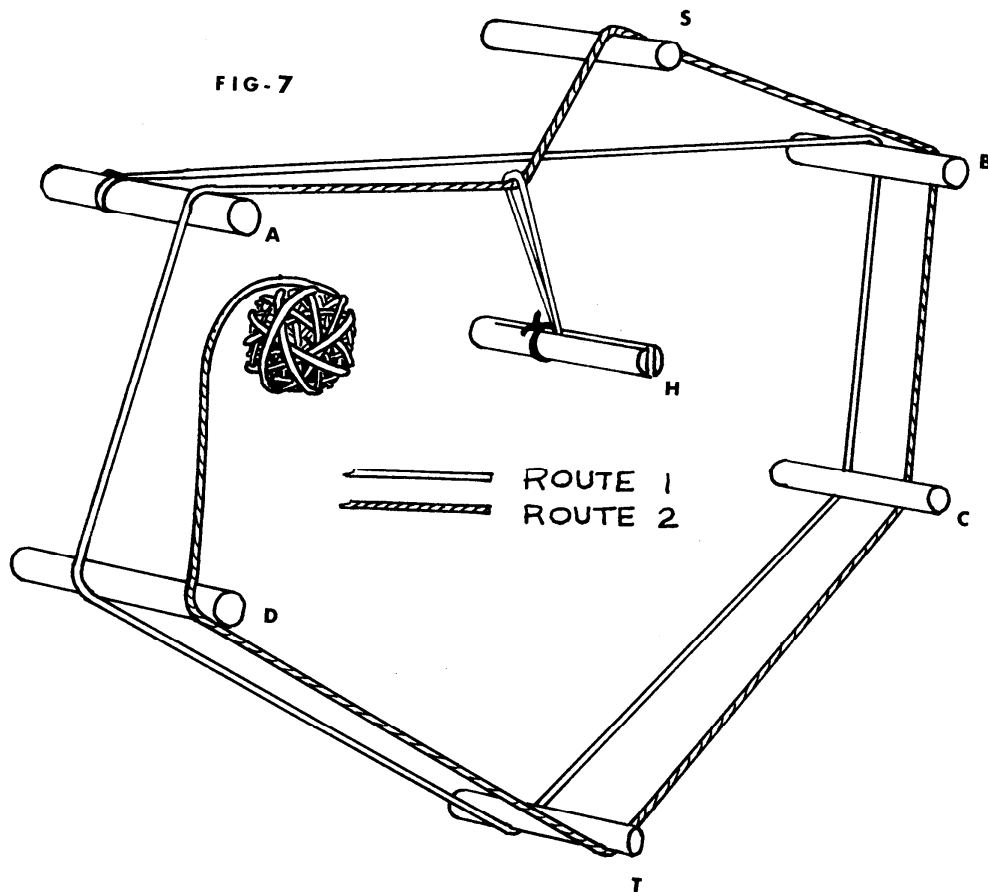

Method 1

To make heddles, place a peg in hole G. Wind a thread around peg A and peg G and tie in a firm knot. In this way all heddles will be the same length, which is important (Fig. 7-A).

Remove heddle from pegs A and G. Place it on peg H and slip it through slot, under and up. Now warp loom, passing each thread that goes over peg S (upper warp) through a heddle (Fig. 7).

Heddles—Lisses

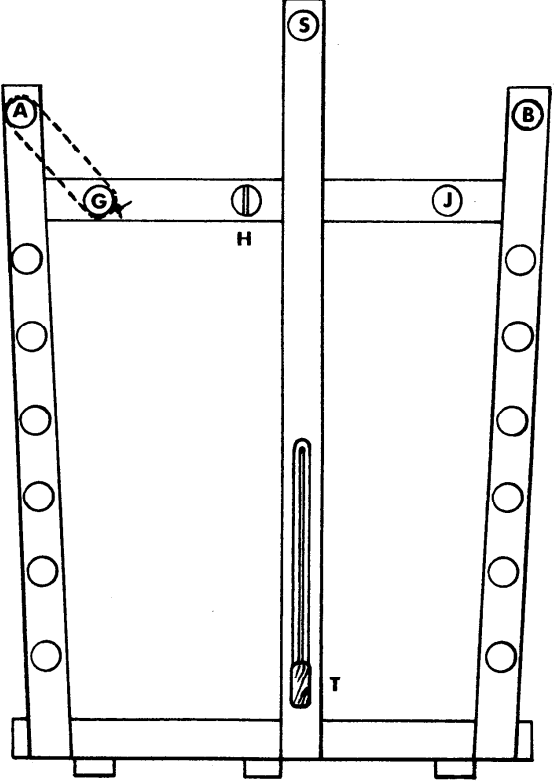

Method.2

FIG. 7B

Method.1

FIG. 7A

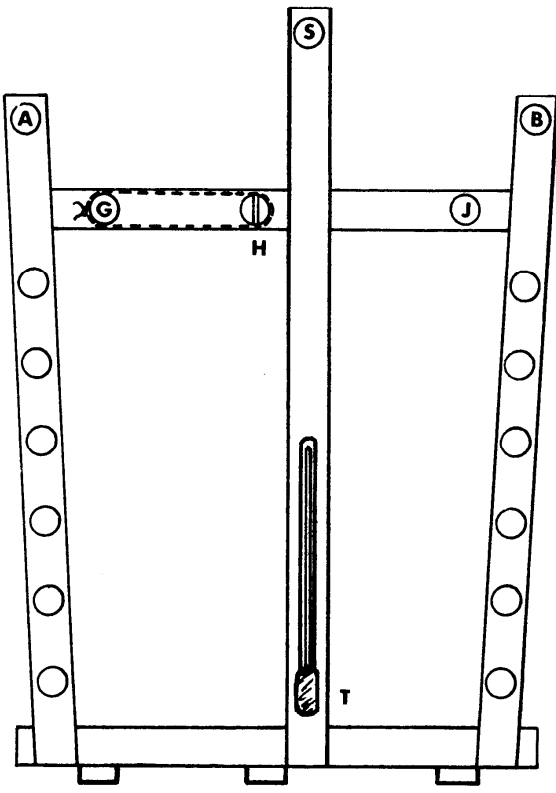

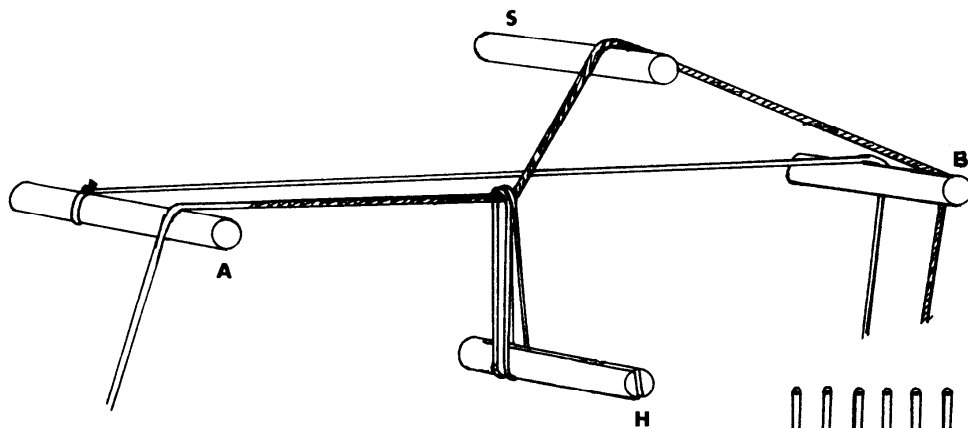

FIG - 8

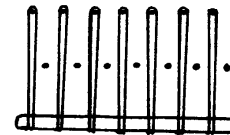

FIG - 9

Method 2

Make heddles first. Make as many heddles as you will need for the total number of threads that will go over peg S

To make heddles, first place a peg in hole G. Then wind thread around peg H and peg G and tie the ends in a firm knot. (Fig.7B)

Remove one end of heddle from peg G. Guide it between first two threads on the lower warp, up and around the first thread that goes over peg S (upper warp) and back down to peg H, returning between the same two lower warp threads. Take the second heddle up between the second and third lower warp threads, around the second thread on peg S, and return to peg H as before (Fig. 9).

Continue this way until each upper warp thread runs through a heddle.

WARPING THE LOOM

The warp yarns are wound on the loom in two alternating routes.

Tie warp to peg A to start winding. This is later removed.

Take thread over the top front peg A, over the top back peg B, under the lower back peg C, under or over the tension peg T, under the lower front peg D, and back to A again.

Now continue over peg A, through the empty heddle nearest the upright (for Method 1), over S and B, under C, under or over T, under D, and back to the start of the route at A. (See Fig. 7)

For Method 2: Tie warp to peg A and directly from A to B for one route, and from A pass to peg S then B for the other route. All even numbered warp threads must be on peg S, and all odd numbered threads must be direct from A to B. (See Fig. 8)

The warp must not be fixed permanently to any peg, so that it will turn freely as the weaving progresses. When the warp is finished, tie the end firmly to the last thread. Untie the first warp thread from peg A and tie it to the adjacent thread.

Now wind a warp on the loom, using a smooth cotton yarn such as pearl cotton. Be sure to use the two alternating routes. The warp can be made more interesting by winding a dark color four times, then a light color four times. Start by making a half bow of the dark yarn at peg A. When you have wound the dark yarn four times to make four warp ends, cut the last strand a few inches longer than the others. Now untie the half bow and tie the start of the light yarn to the end of the dark yarn. The warp you are making is a continuous one, which is pulled toward the weaver as the weaving progresses, so do not tie the yarns to any of the pegs, only to other yarns.

Repeat the process with the light yarn four times, then the dark yarn, and so on.

Continue until you have a warp about as wide as the shuttle that comes with the loom. (1 1/4"). A fine warp will require more winding than a coarse one; pearl cotton No. 3 will make a warp more quickly than No. 5.

Finish the warp with four strands of the dark color, just as you started. When making a draft (pattern) for a warp add an extra thread once (5 threads) in order to finish with an odd number of threads (ends). This extra thread should not be added at either edge of warp, but some where in the middle.

The inkle loom weaves warp-faced fabric, which means that the weft yarn carried by the shuttle shows very little (just at the edges of the band being woven).

A special weaving technique is used to control the warp-faced effect. This control is most easily learned by having a warp on the loom and using the weaving technique described previously.

After the warp is wound, tighten the tension by adjusting the tension peg T so that a springiness remains in the warp. Grasp the warp in front of the heddles and pull the warp toward you. See how the heddles also move toward you. Now push the heddles back with the flat side of the shuttle, underneath the warp, and you will see that they straighten up again. It is important to push the heddles into a more upright position each time you advance the warp, so as to keep a clear shed.

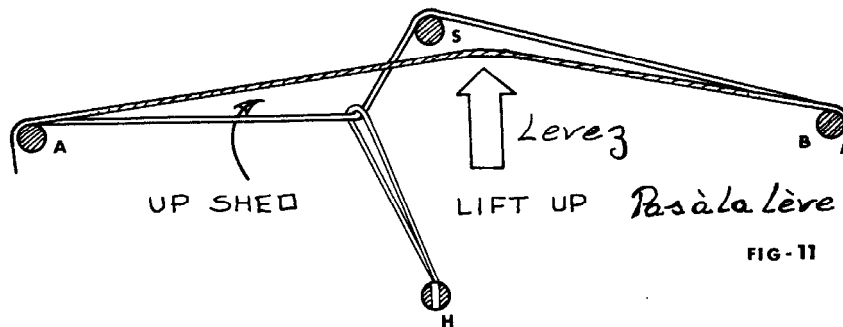
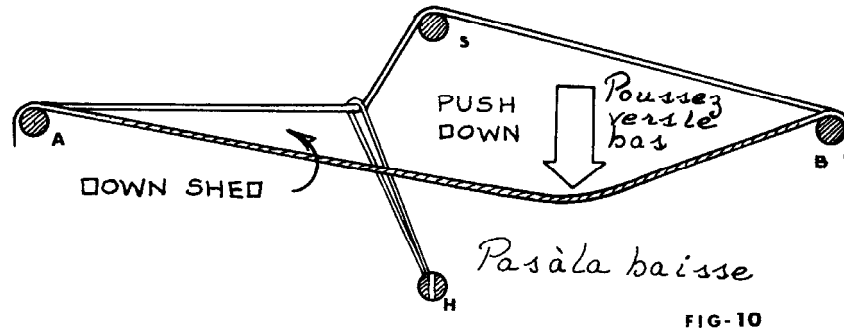

Now look at Figures 10 and 11. You will see that two sheds (openings in the warp) can be made on the loom, one by pressing down on the straight line of warp between pegs A and B, and the other by lifting up on the straight line of warp. Press up and down in the space between the heddle peg H and the back peg S.

Using the same color yarn with which you started and ended your warp, fill the shuttle. Cut the yarn free from the ball and leave an end of yarn dangling from the shuttle.

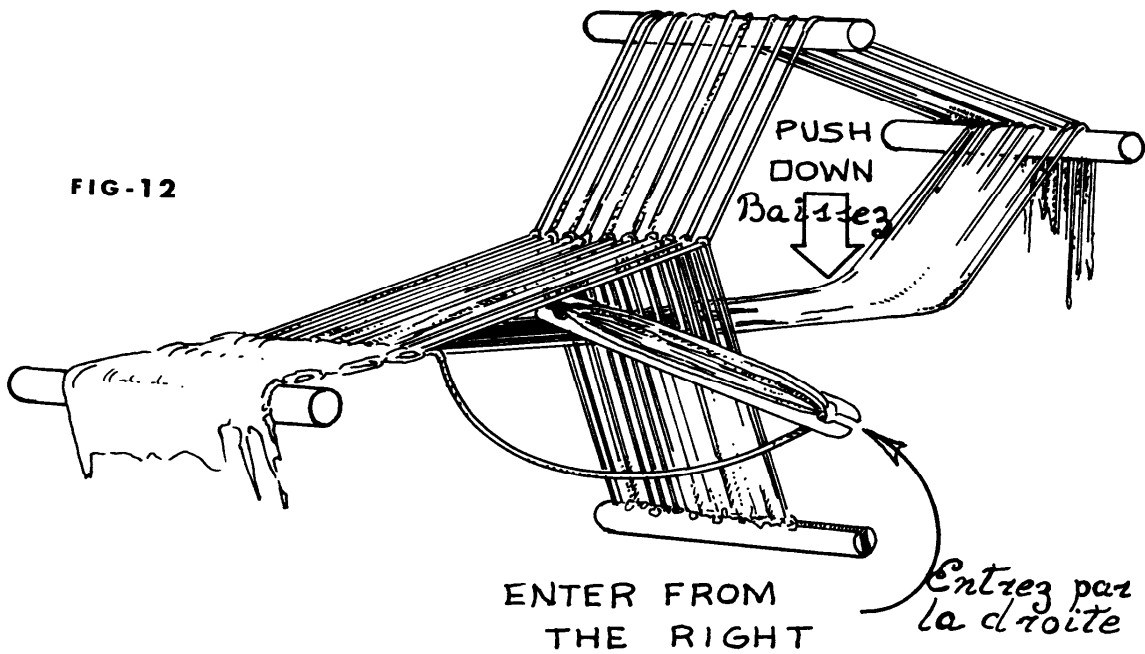

Make a down shed by pressing on the straight line of warp behind the heddles, using your left hand. Place the shuttle in the shed that is now open, between the heddles and peg A (see Fig. 12). It is important to have the sharper edge of the shuttle facing you. Now release the pressure exerted on the warp by your left hand and grasp the shuttle with this hand. Pull the shuttle to the left, leaving a few inches of weft yarn dangling free at the right edge of the warp.

FIG-13

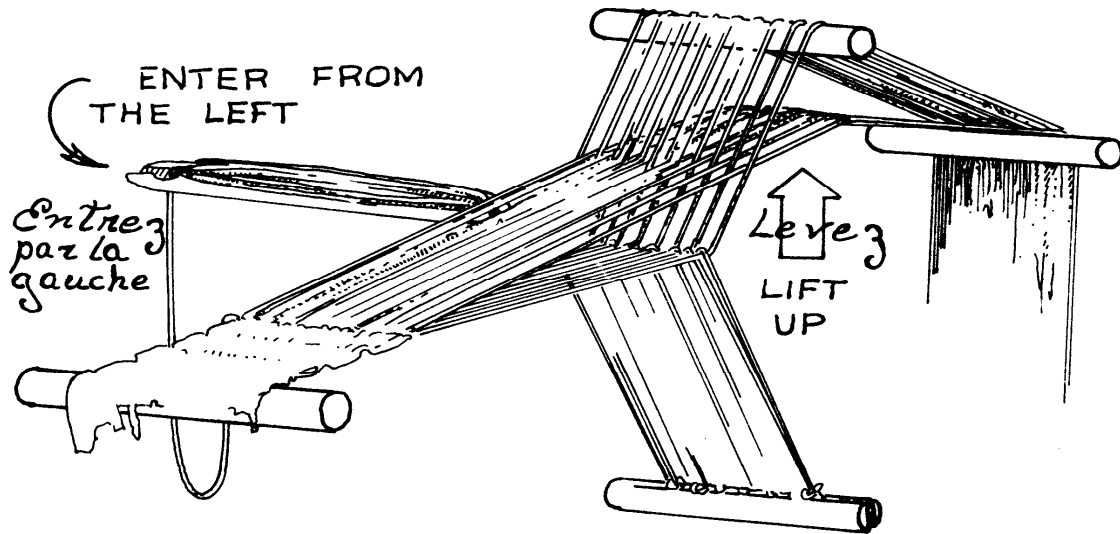

Make an up shed with your right hand and place the shuttle in the shed from the left side (see Fig. 13). It will be easy to remember which shed to make if you lift the warp when entering it from the left. Grasp the shuttle with your right hand and pull it to the right, drawing the weft thread through the shed. A small loop of yarn may remain at the left-hand side of the weaving and this must be corrected by adjusting it after you make the next shed change. Always correct the tension of the weft yarn after you have changed the shed, by pressing the sharper edge of the shuttle against the last line of weft

and pulling on the weft yarn so as to draw the warp yarns closer together. This is the method of controlling the warp-faced effect, referred to on page 8.

After a few inches have been woven in this way, the weaving will be closer to the heddles and there will be less space for the shuttle to move in. You will then need to pull the warp toward you in order to bring forward a new area for weaving. It may be necessary to release the tension on the warp by adjusting peg T, so that the warp will be easier to move around the pegs.

Continue weaving in this manner until the beginning of the weaving reaches the back peg B, or a little beyond this point. It will then become difficult to make a clear shed.

To secure the weaving so that it does not unravel, thread a tapestry needle with some of the weft yarn and whip the last line of weft to the one just before it. Do the same at the beginning of the weaving, using the yarn left free when you started using the shuttle.

Weaving bands of striped colors will not interest you indefinitely, so consider other possibilities. To make your own designs you will need a vocabulary of warp effects. To convey these effects to one another, weavers use a set of symbols called a threading draft, which is a graphic representation of all the warp yarns used in warping a given design. Only the simple drafts used for inkle looms will be discussed here.

The symbols used are written on two lines, corresponding to the two warp routes shown in Figs 7 and 8. The draft is read from left to right, as the loom is warped from left to right.

A symbol on the lower line refers to a warp yarn going straight from A to B. A symbol on the upper line refers to a warp yarn going through a heddle and then over stretcher peg S before it goes to peg B.

The symbol indicates the color of the yarn as well as its route, since no pattern draft would be needed if only one color were being warped. Now look at Fig. 14. You will see the striped band you have woven portrayed in two ways: one in the set of symbols called a draft, and a drawing that shows how the fabric appears when woven according to the draft. Figures 14 to 19 each show a different draft, for a variety of effects.

A good selection of colors in suitable yarns will encourage the creation of many new effects. Fuzzy yarns should be avoided by the beginner. Pearl cotton has already been mentioned. Plied linen makes a smooth, firm warp. Hard twisted worsted yarns are also good. Colorful yarns and different drafts can be combined in countless ways. There are no bounds to imagination and inventiveness.

Patrons de tissage

DRAFTS

VERTICAL WARP STRIPES

Bandes Verticales



couleur foncée  = DARK COLOR
couleur pâle  = LIGHT COLOR



WHEN WOVEN
après le tissage

FIG-14

WAVY VERTICAL LINES

Vagues en lignes Verticales

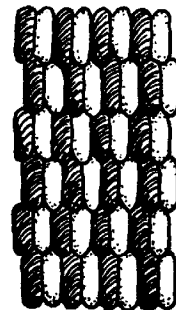

FIG-15

HORIZONTAL LIGHT BARS ON A

DARK BACKGROUND

Barres horizontales

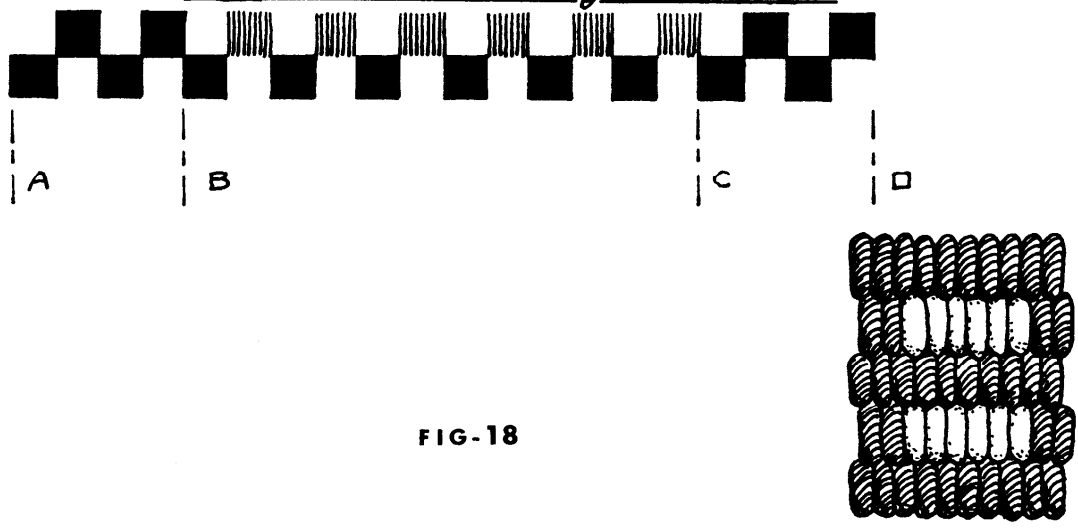

FIG-18

ALTERNATING LIGHT AND DARK BARS

Barres alternant, pâles et foncées

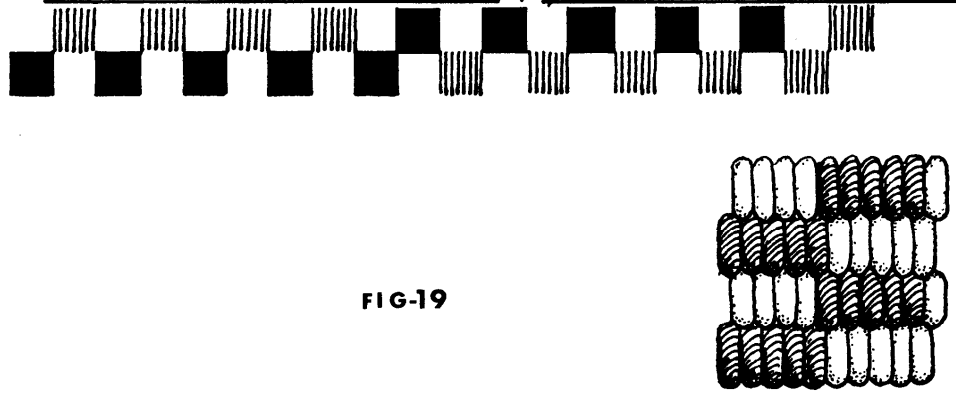

FIG-19

WARPING FRAME

To make a warp on the "Cendrel" loom:
Attach a thread (or threads, two or four) to starting peg T as on Figs. 20 and 21, or E on Fig. 22. Using one thread, yarn must be carried around the pegs as many times as you want threads in the warp. Using two threads only half as many complete turns are necessary, and using four, only one-quarter as many.

Take yarn around pegs on frame as illustrated, make a cross at top between G and H on Fig. 20 or H and J on Fig. 21, and return to starting point, following the same pegs, until you have the number of threads needed for your warp.

Always keep the tension even when placing yarn on warping frame; all threads should lie flat on the pegs. When using more than one thread (two or four), separate all threads by putting your fingers between them and make sure that they are always wound in the same order.

When you want to change color, cut thread (leave an extra two inches), pass it around one peg end (either starting peg T or end of cross G, Fig. 21), tie it to a thread of a different color, and continue warping.

Be sure to always make the cross in the same manner (around the same pegs).

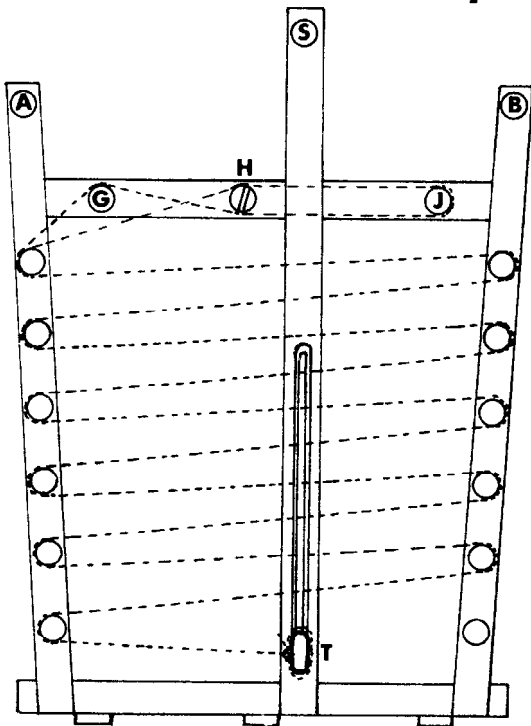

8-Yards.
8-Verges.

FIG- 20

Put three pegs (G, H, J) on upper cross piece (8) to use for cross. Place as many pegs as needed on upright pieces (5, 7), depending on length of warp required. Using all pegs under cross piece (8), starting with T in center upright, over to lower left-hand side peg, and continuing up the frame, makes a warp eight yards long.

For a ten-yard warp, place pegs on top of posts (A, S, B), start at center lower peg T, over to the lower right-hand side peg, and continue up the frame. (Fig. 21).

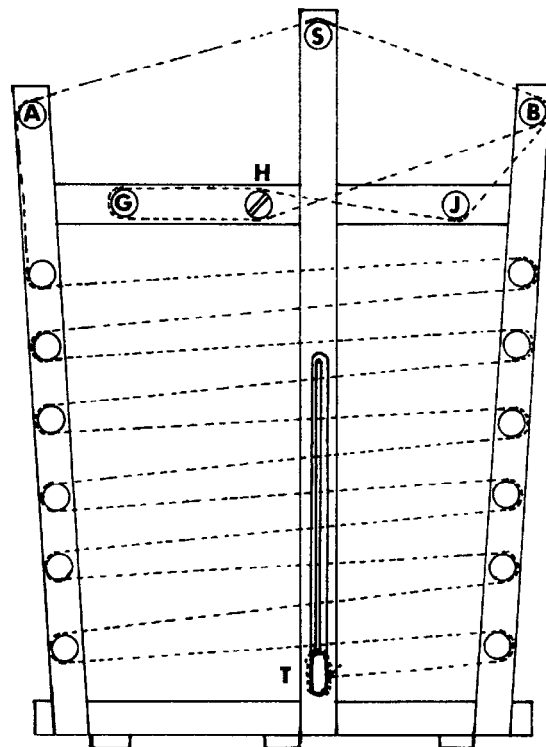

10-Yards.
20 10-Verges.

FIG- 21

Insert the cross sticks through the two parts of the cross and tie them securely together at each end [Fig. 23].

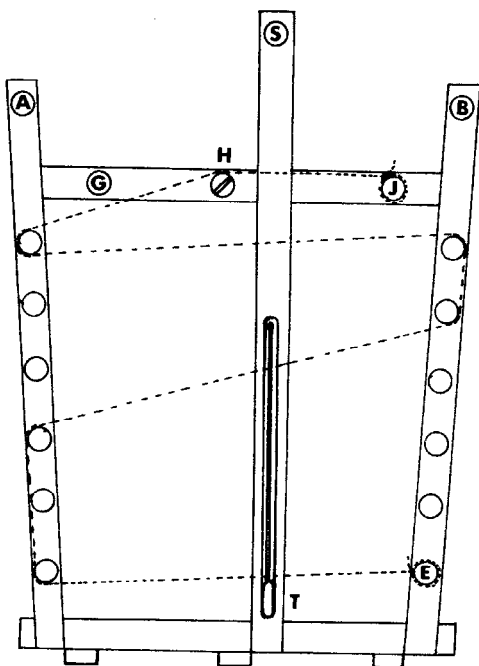

FIG-22

For any other measurement cut one thread of the desired length, place it at the cross and wind it around the pegs, either vertically or horizontally, until the end of the thread is reached. This will determine which pegs to use for your warp. Do not forget to include the cross in your measurements. (See Fig. 22.)

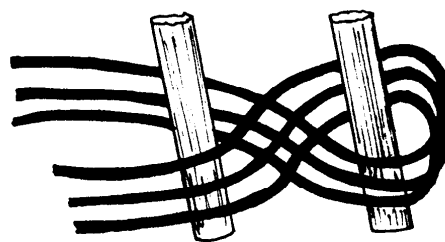

FIG.- 23

To chain the warp and prevent tangling, grasp the warp firmly and slip the loop off the end peg. Place the right hand through the loop and grasp the entire warp, pulling through far enough to form another loop. Continue thus to the end of the warp. (Fig. 24).

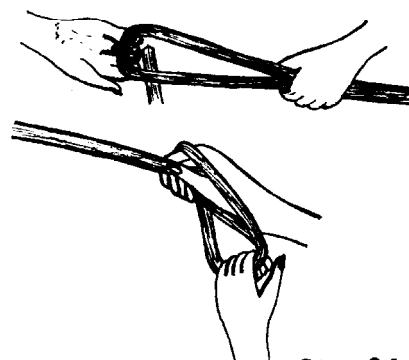

FIG.- 24

Depending of the effect you want to make, you can cut off other threads than those at the center, as long as they are not too close to the edges.

However, note that you have to cut off two threads on each side which makes four instead of only two and then, take them off at every two inches instead of at every inch.

When you want to widen the neck-tie, approximately fifteen inches after you finish the narrow part, readjust your threads by taking the two last ones you had cut and then subsequently attaching to the following ones at every inch. Fix them on the weaving part with the help of a pin. Be careful to give them the same tension as the whole warp.

If you wish to have a width of 2 1/2 inches at the end of your neck-tie from the 36 threads which remain on the narrow part, you have to re-tie the threads until you have 60 in use. There will be 12 remaining that are not used.

It is necessary to finish your neck-tie very carefully in order to have a good quality product. Take the threads which have been cut and with a round point needle, weave them into the back side of the neck-tie.