

Leclerc Looms

Since 1876



1573 Savoie
C. P. 4 Plessisville, Qc.
G6L 2Y6
TEL: 819-362-7207
FAX: 819-362-2045
www.leclerclooms.com
info@leclerclooms.com

On receiving the loom, unpack and lay out the loom components .
Do NOT discard any packing material until all parts are inventoried.

Check the parts received against the parts list on pages #2 to #7 of the assembly instructions.
Report any discrepancies to Leclerc immediately.



To assemble this loom, a minimum of 2 people are needed but it is recommended you use 3.

MIRA II

36"	4230-0136
45"	4230-0145
60"	230-0160

Prepared by: _____

Inspected by : _____

Date: _____

PARTS LIST

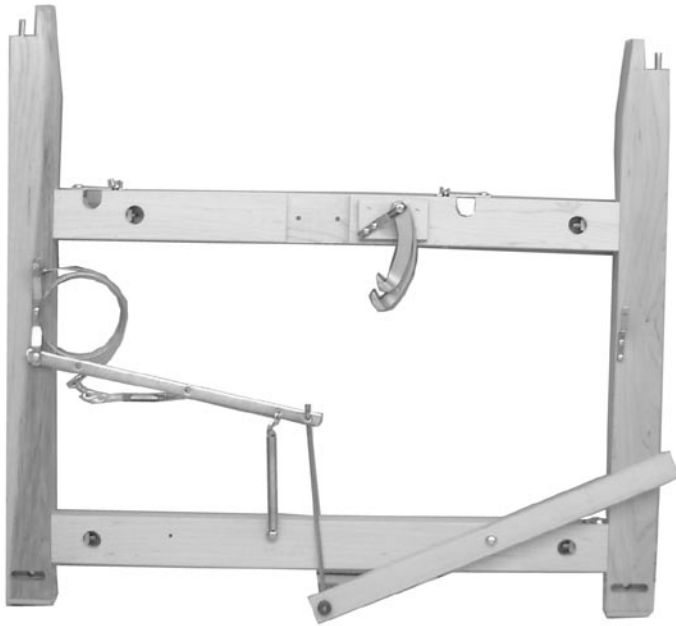

1 right-hand side of loom



1 left-hand side of loom

6 treadles

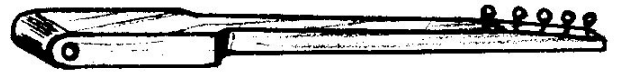

2 metal treadle supports

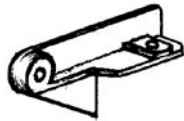

1 treadle set rod with
1 Push nut 7/16"

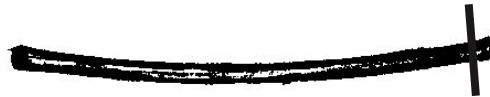

1 more treadle set
push nut 7/16"



1 warp beam advance
control system



2 screw no 12, 1"

LECLERC NOTE IN FRENCH:

1) Faire le trou sur le montant centre pour l'attache du ressort de régulateur. 1" plus haut que le crochet arrière.

2) Faire les trous pour le frein d'ensouple

3) Faire les petit trous dans les montants pour les baguettes d'encroix.

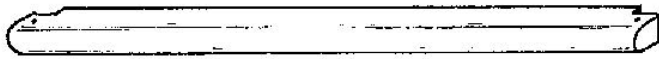

2 breast beams
(43½", 52 5/8")

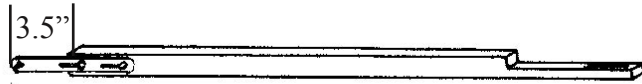

1 left sword (32½")



1 right sword (32½")



1 cloth (front) beam
(38½", 47 5/8", 62 9/16")



1 warp (back) beam
(38½", 47 5/8", 62.9/16")



1 batten handtree
(46¾", 55 3/4", 70¾")

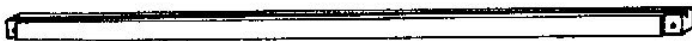

1 batten sley with shuttle race (46¾",
55 3/4", 70¾")

No holes

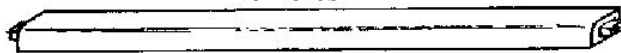

1 back cross-member (40 1/8", 49", 64")

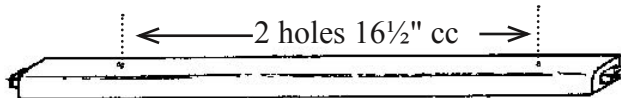

1 treadle set cross-member
(40 1/8", 49", 64¾)

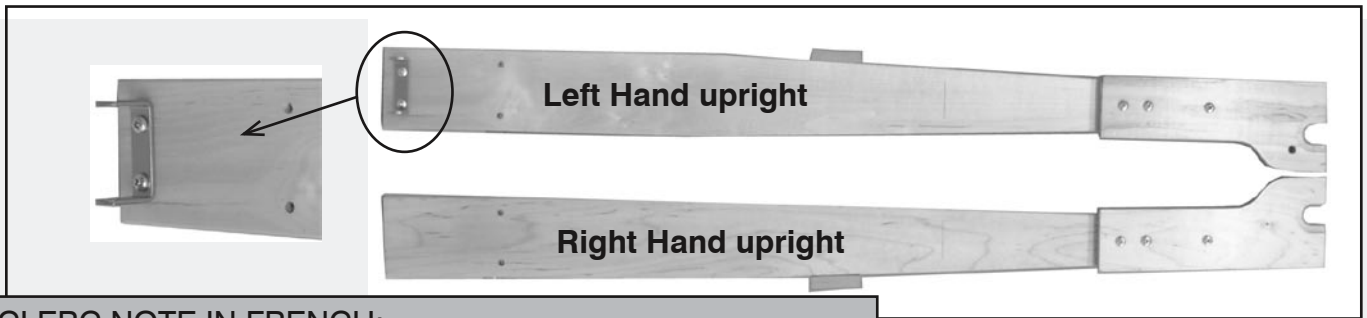

LECLERC NOTE IN FRENCH:

- 1) Faire le trou sur le montant centre pour l'attache du ressort de régulateur 1" plus haut que le crochet arrière.
- 2) Faire les petit trous dans les montants pour les baguettes d'encroix.

1 apron



1 cloth take-up motion handle

NOTE:
Avec la rondelle de bois

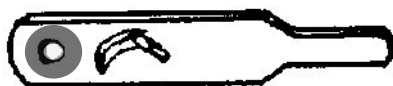

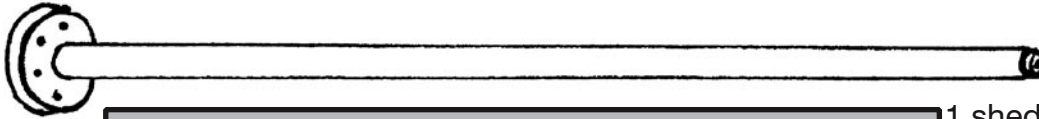

1 shed regulator roller

Note for Leclerc in French: Vérifier les petits trous sur la poulie , sur les rouleaux de tête et octogonale.

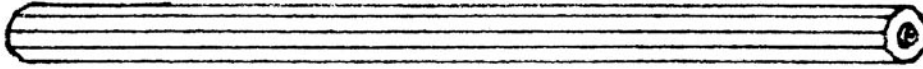

1 octagonal roller with white pulleys

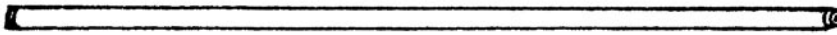

2 small rollers with white pulleys

Note for Leclerc in French: Utiliser des vis avec épaulement pour les poulies des petits rouleaux.



1 metal pin to lock shed reg. roller



1 open eyehook



9 round-headed screws No 6, 1/2"



9 steel washers 3/16"



1 shed regulator spring

5.5" + Crochet en "S"

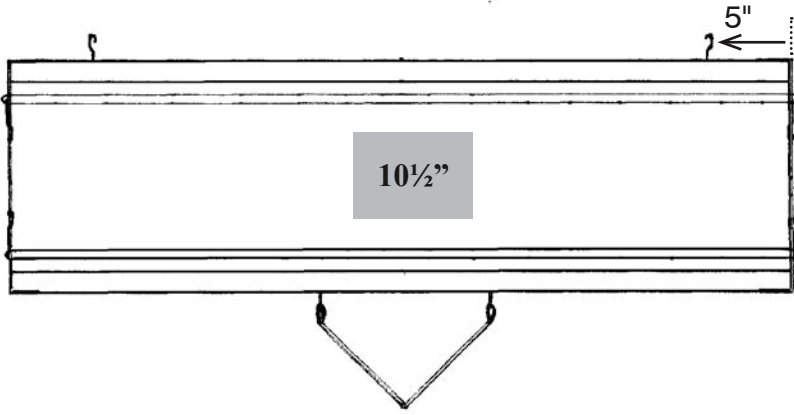

4 shaft frames



4 lams

36" = 26 1/4"
45" = 30 3/4"
60" = 38 1/4"

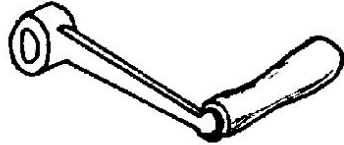

1 crank

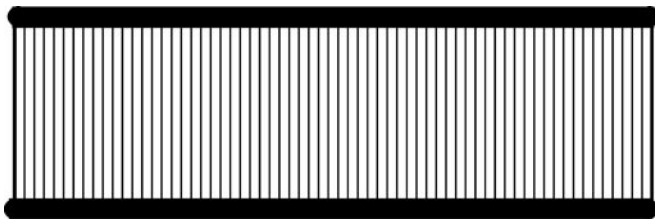

1 reed



2 lease sticks



4 warp rods



3 screwdrivers (black, red and green)



1 adjustable wrench

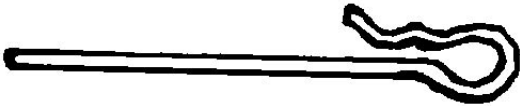

1 set of 6 treadle hooks 7" # 3500-4521



1 set of 12 treadle cords 7" #3000-7011

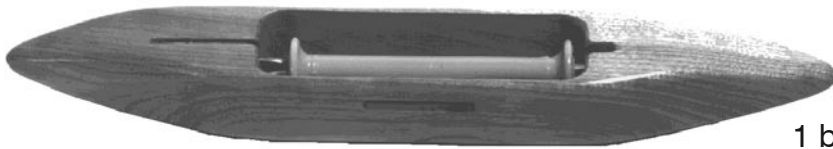

1 boat shuttle regular size



12 plastic bobbins 4"



1 threading hook with plastic handle



2 pk cord - 5 yd each



10½"

1000 heddles (36" loom)
1200 heddles (45" loom)
1500 heddles (60" loom)



2 loop cords 17" (Shed Regulator roller p.13)
2 loop cords 30" (Middle roller p.14)
4 loop cords 20" (Lower rollers p.15)
1 loop cord 45" (Shed regulator p.16)

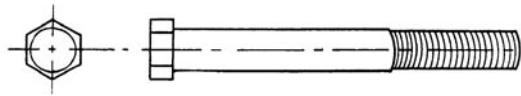

Machine bolts
 4X - 3/8" x 5"
 1X - 1/4" x 3"

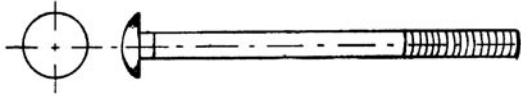

Carriage bolts
 6X - 5/16 x 2 1/2"
 2X - 5/16" x 2 1/4"
 4X - 1/4" x 2 1/2"



5X - 1/4"
 10X - 5/16"
 2X - 9/16"
 4X - 3/8"



Hexagon Nuts
 2X- Nylon auto lock 5/16"



Wooden spacer
 5X
 1"



Square nuts
 4X - 3/8"
 5X 5/16"
 1X - 1/4"
 4X - 1/4"

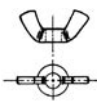

Wing nuts
 4X - 5/16" (8 mm)



2X Eye screws

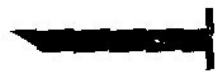

"Tacks" for apron



1 instruction Video showing all stages of the Fanny II installation.

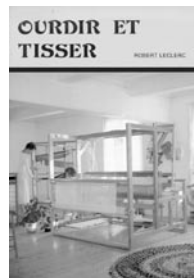

1 Warp & Weave

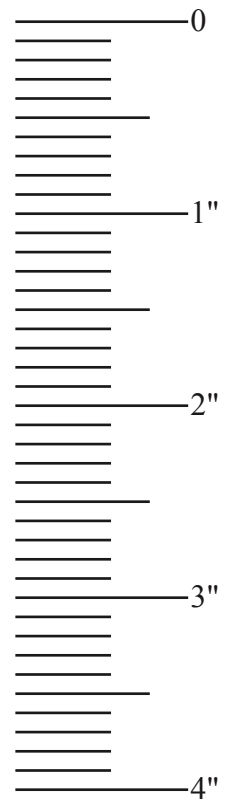

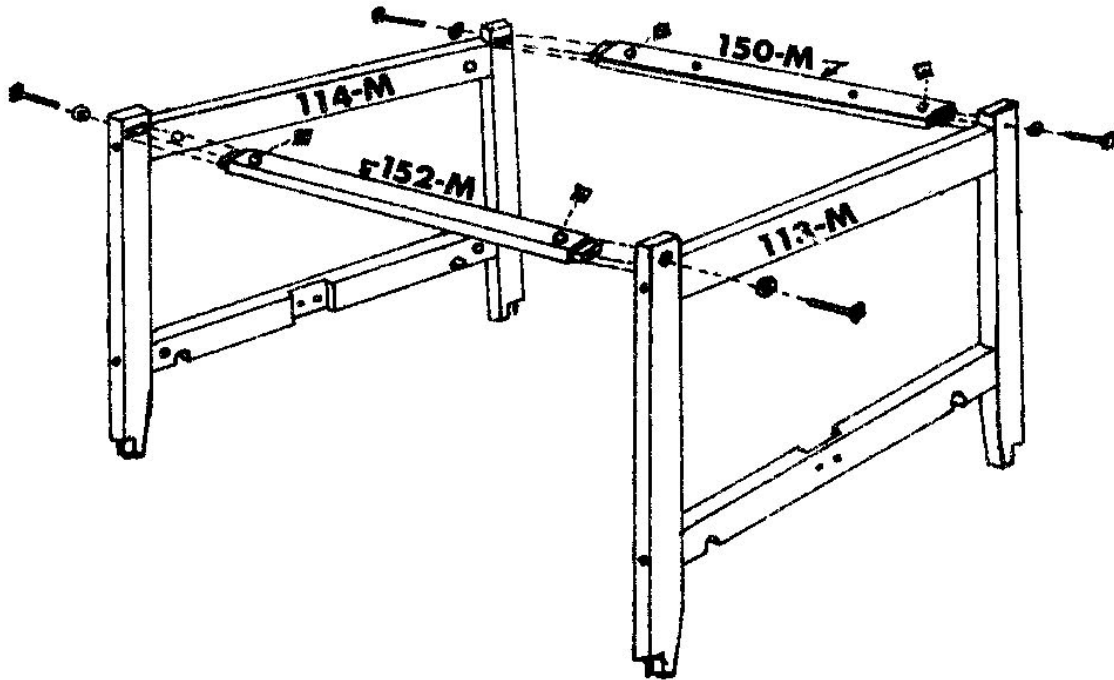

Take the 2 sides of the loom already assembled, place them on the floor upside down.

Insert the tenon of lower cross-member 150-M and 152-M into the lower mortise of the sides of the loom.

The round edge of the cross-members goes in the top (bottom here because the loom is now upside down) front for the front piece and in the top back for the back piece.

The lower front cross-member 150-M has two holes drilled through it which are used to affix the treadle set.

Using the wrench supplied with the loom, affix cross-members with a 3/8" x 5" machine bolt, a 3/8" steel washer and a square nut.

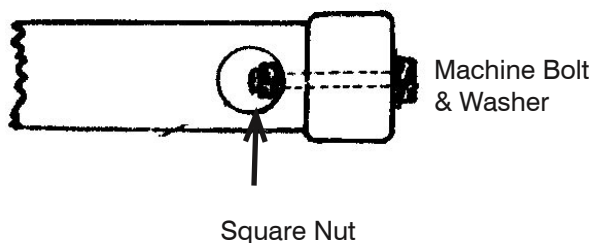

EMPTY PAGE To Match the Fanny II DVD video

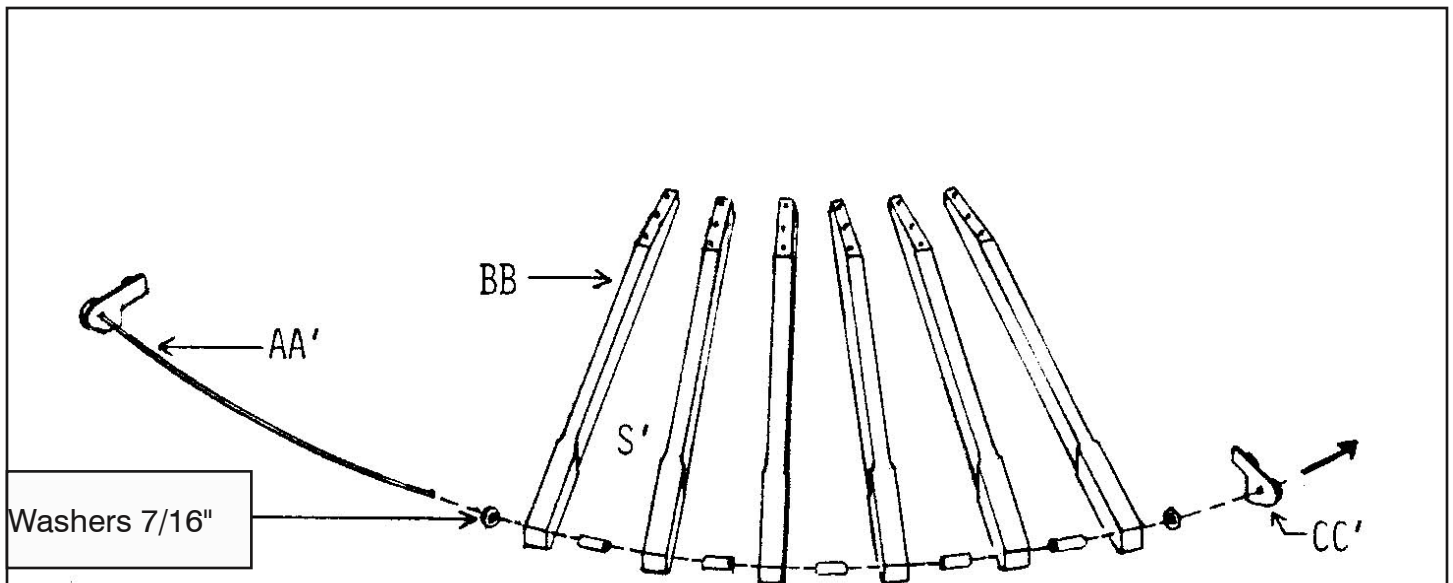

- Assemble the treadle set as illustrated using:
- 6 treadles
 - 5 wooden spacers 1"
 - Treadle rod pre-assembled
 - Steel Washers 7/16":

Install the second side push nut only after the set is affixed to the loom.

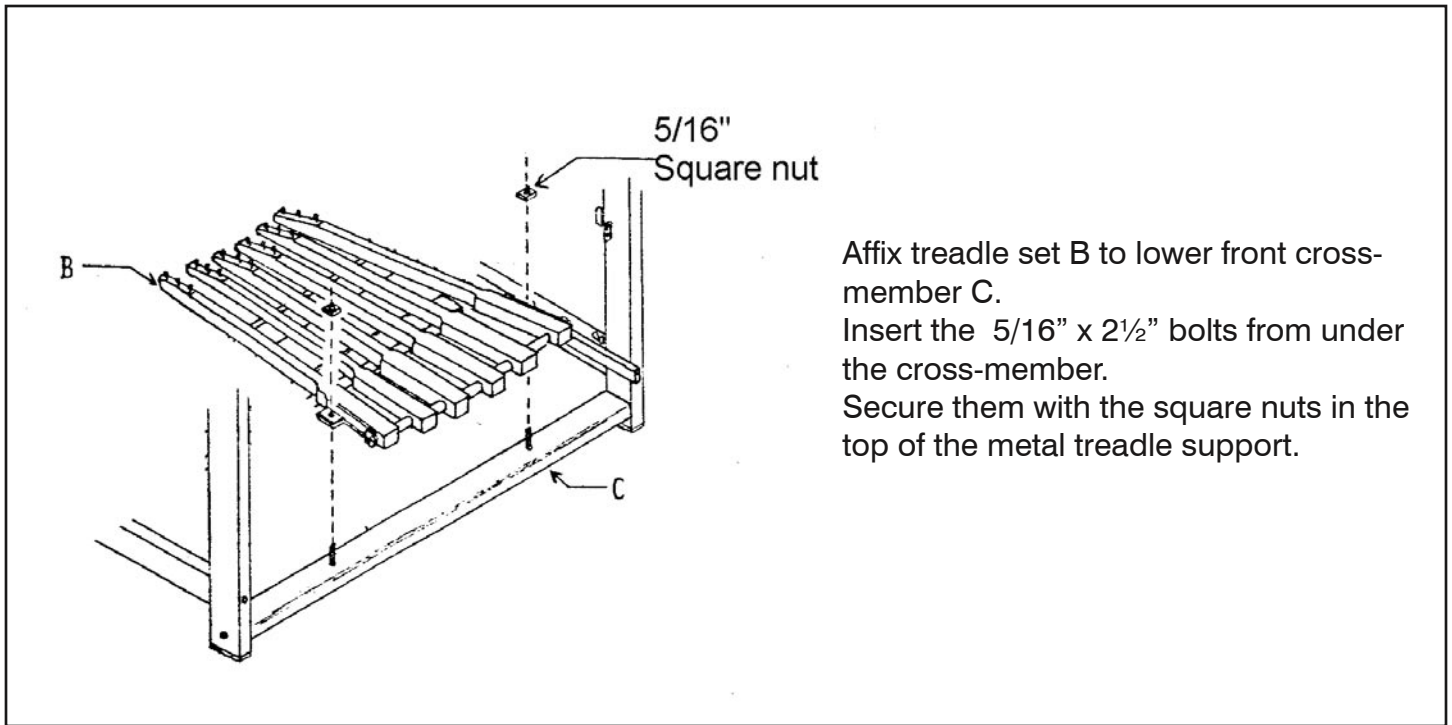

Affix treadle set B to lower front cross-member C.
 Insert the 5/16" x 2 1/2" bolts from under the cross-member.
 Secure them with the square nuts in the top of the metal treadle support.

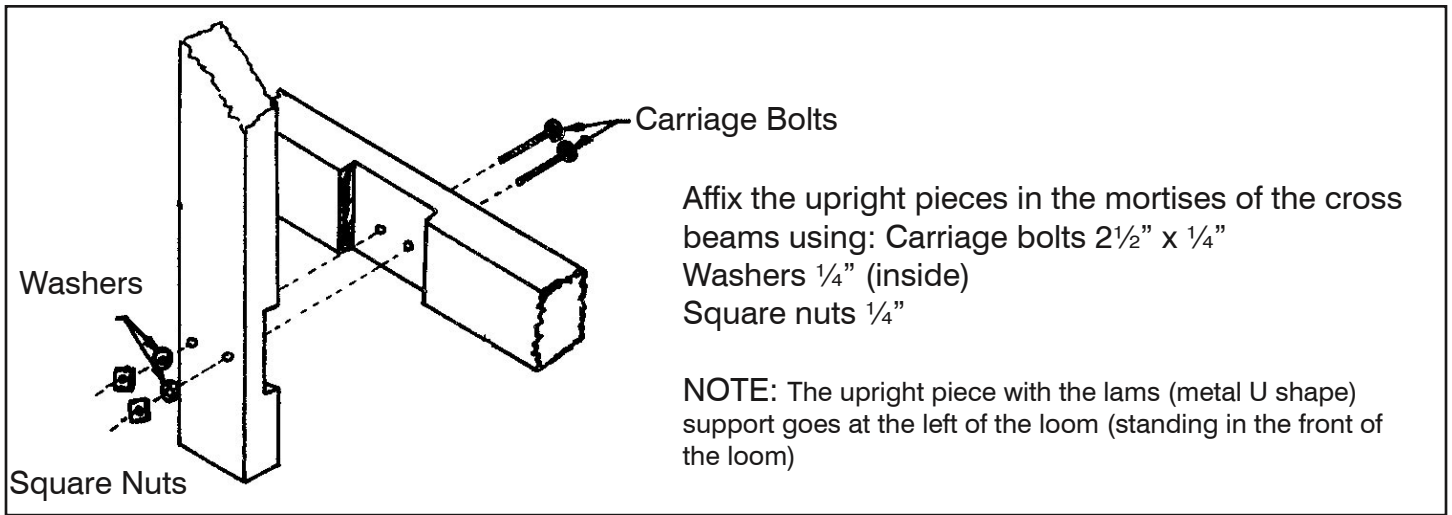

Affix the upright pieces in the mortises of the cross beams using:
 Carriage bolts 2 1/2" x 1/4"
 Washers 1/4" (inside)
 Square nuts 1/4"

NOTE: The upright piece with the lams (metal U shape) support goes at the left of the loom (standing in the front of the loom)

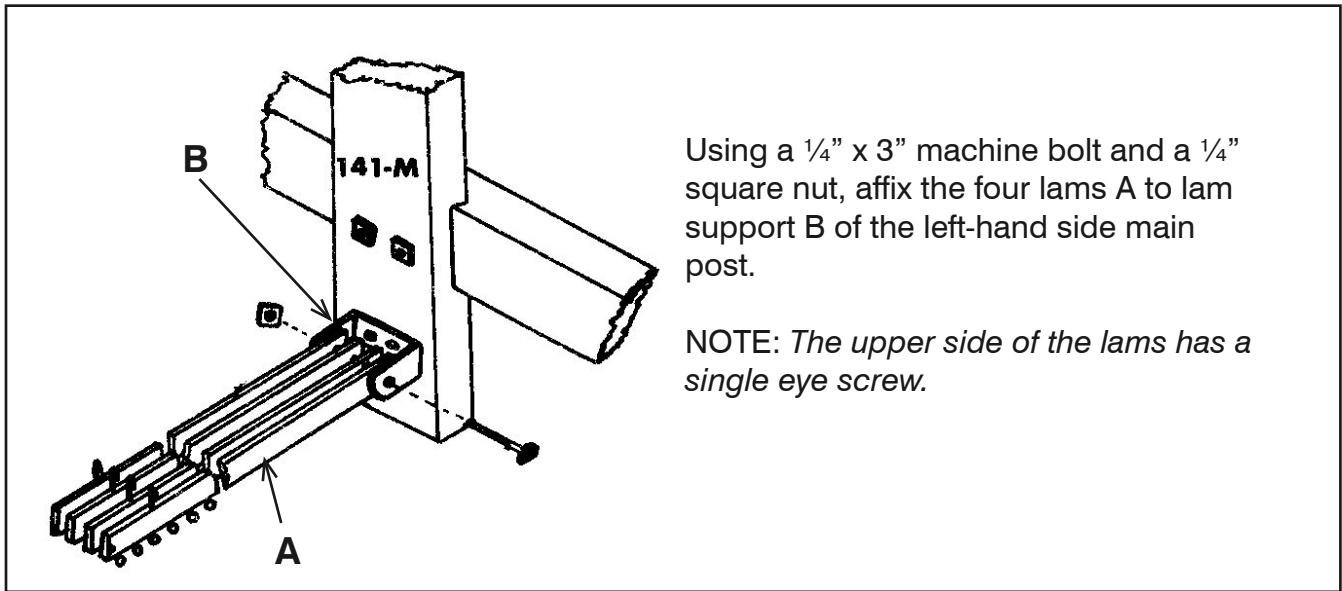

Using a 1/4" x 3" machine bolt and a 1/4" square nut, affix the four lams A to lam support B of the left-hand side main post.

NOTE: The upper side of the lams has a single eye screw.

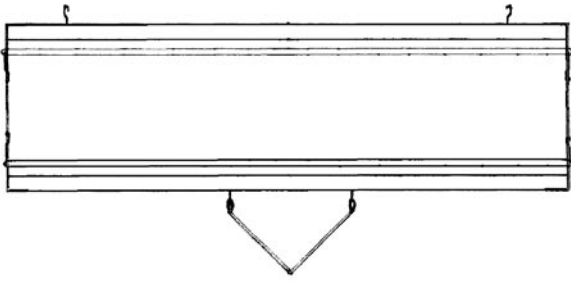

Install the heddles in the shaft frames
(see WARP & WEAVE).

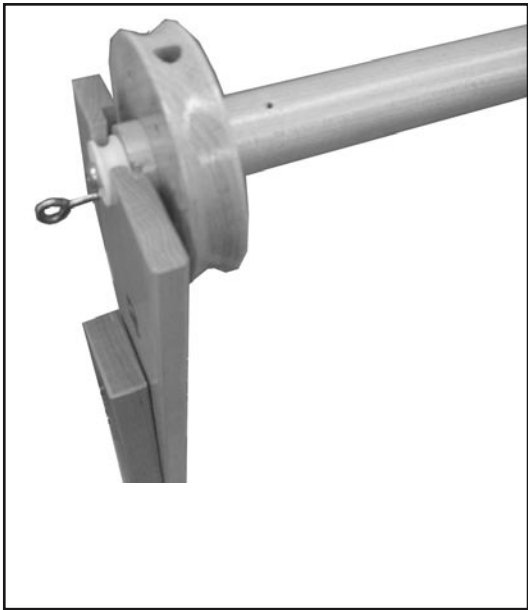
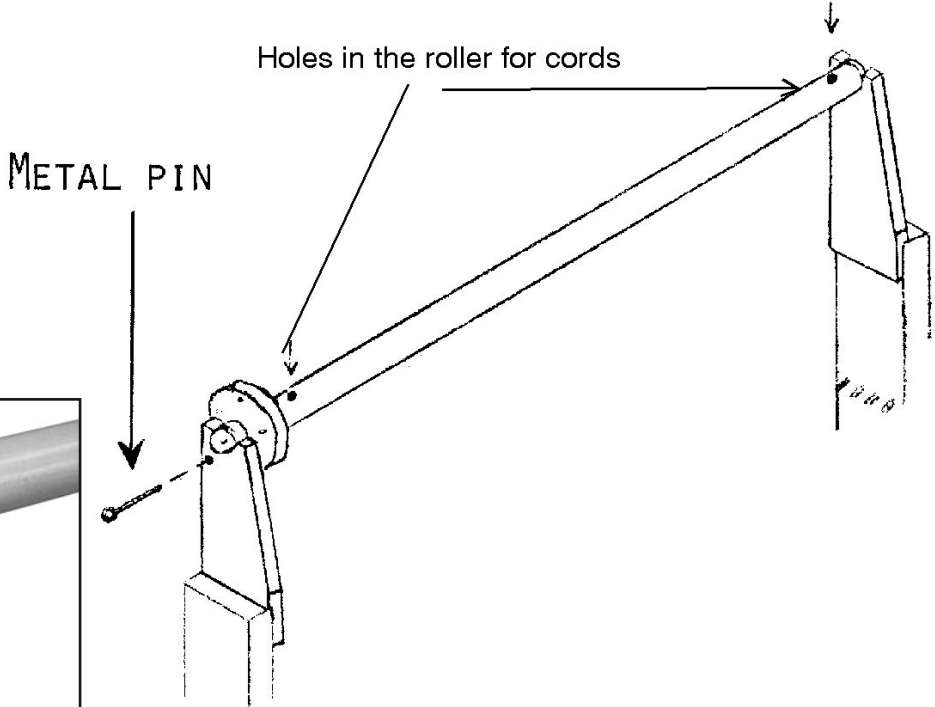
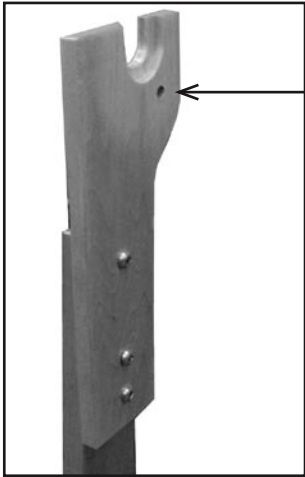

Note #1 The left hand side has a hole in the back of the pin for the pin

Using 1" round-headed screws No 12, fasten the two roller supports to the center posts .

Place the shed regulator roller on the supports. The pulley should be on the left hand side of the loom.

Insert the 3" metal pin through the support and one of the holes of the pulley to lock while the holes in the roller for the cords face upwards.

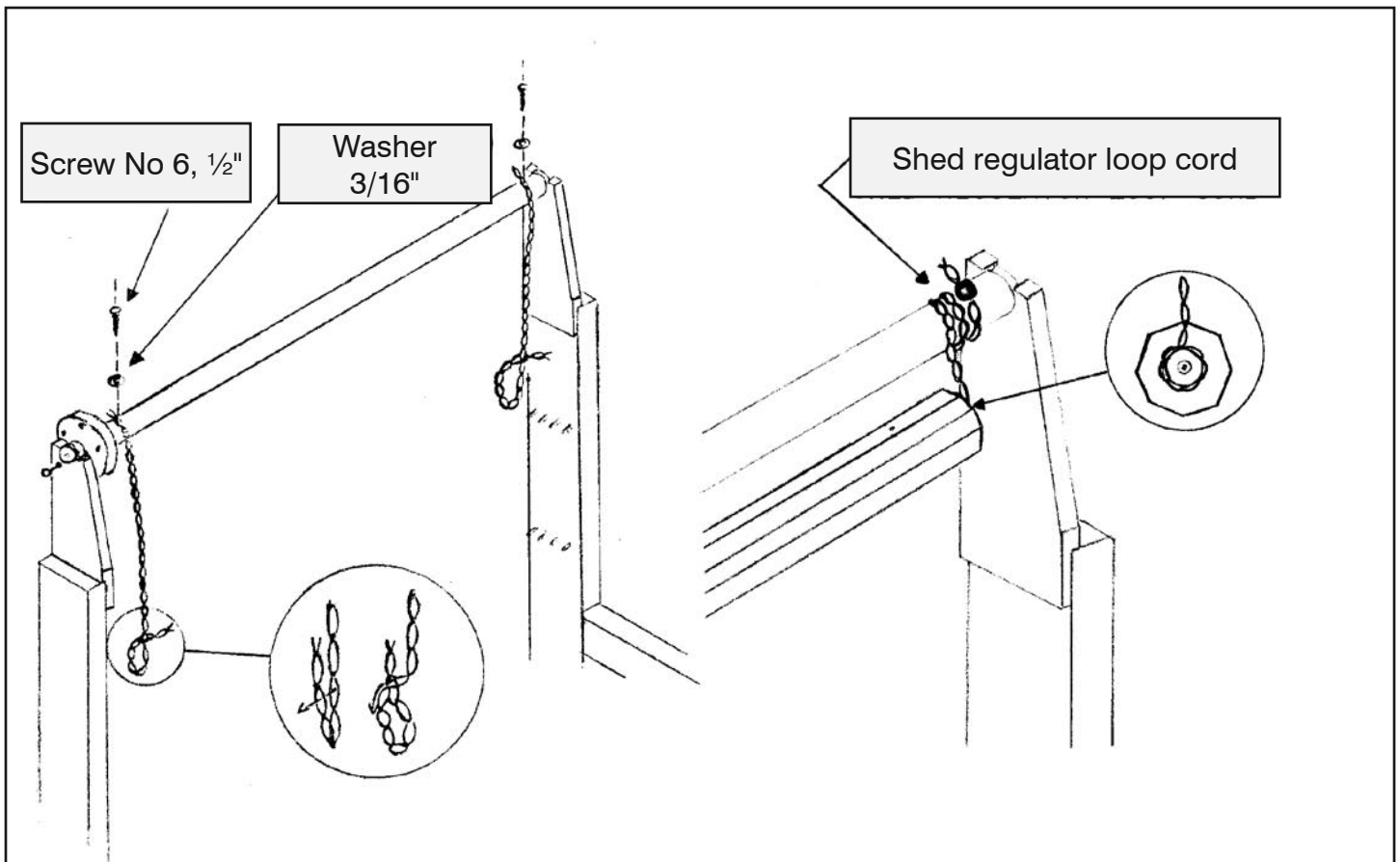

Using a 1/2" round-headed screw No. 6 and a 3/16" flat washer, fasten one end of each of the two 17" loop cords onto the holes on the top of the shed regulator roller.

Make a large loop in the other end of one cord by folding it 3" from the end and drawing the cord through the second last loop.

Commencing with a downward motion from the front to the back, pass the cord around the shed regulator roller twice. Slip the loop around the pulley on the end of the large octagonal roller. Repeat this process for the other side.

Make sure that the distance between the rollers is the same at each end. If not, adjust the loop.

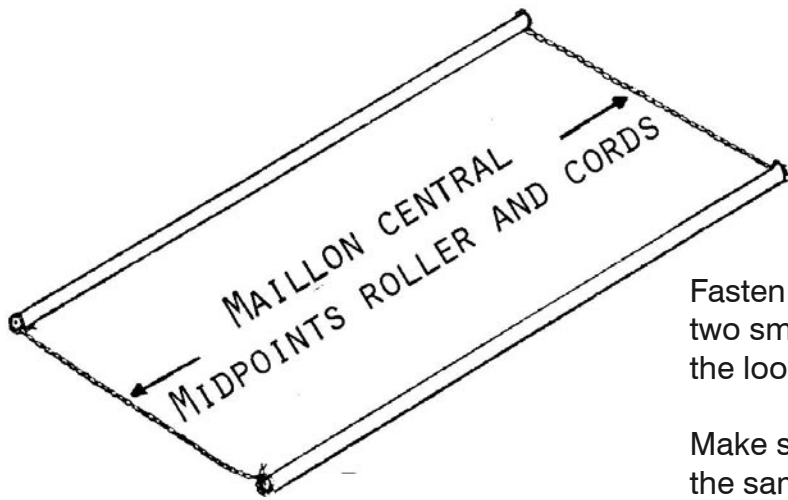

Fasten the two 30" loop cords to the pulleys of the two small rollers by forming a loop at each end of the loop cords as previously described

Make sure that the distance between the rollers is the same at each end.

Fasten two $\frac{1}{2}$ " round-headed screws No. 6 into the holes on the upper side of the large octagonal roller. Do not fully tighten the screw but leave a gap of $\frac{3}{32}$ " to allow for the cord.

Locate the loop closest to the midpoint (Fig. 6) on the cords connecting the small rollers and place under the head of the screws in the large octagonal roller.

Pass the cords (connecting small rollers) once around the large octagonal roller.

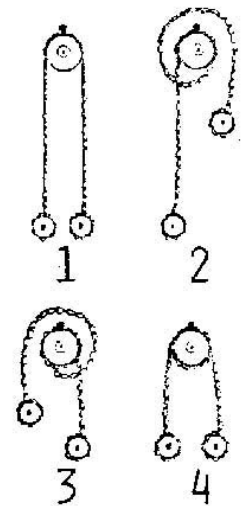
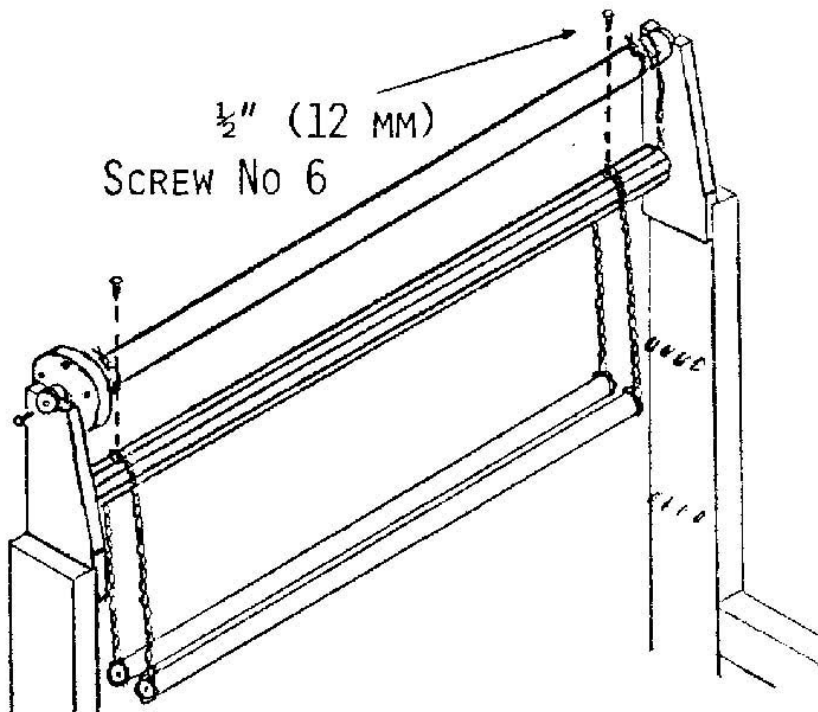

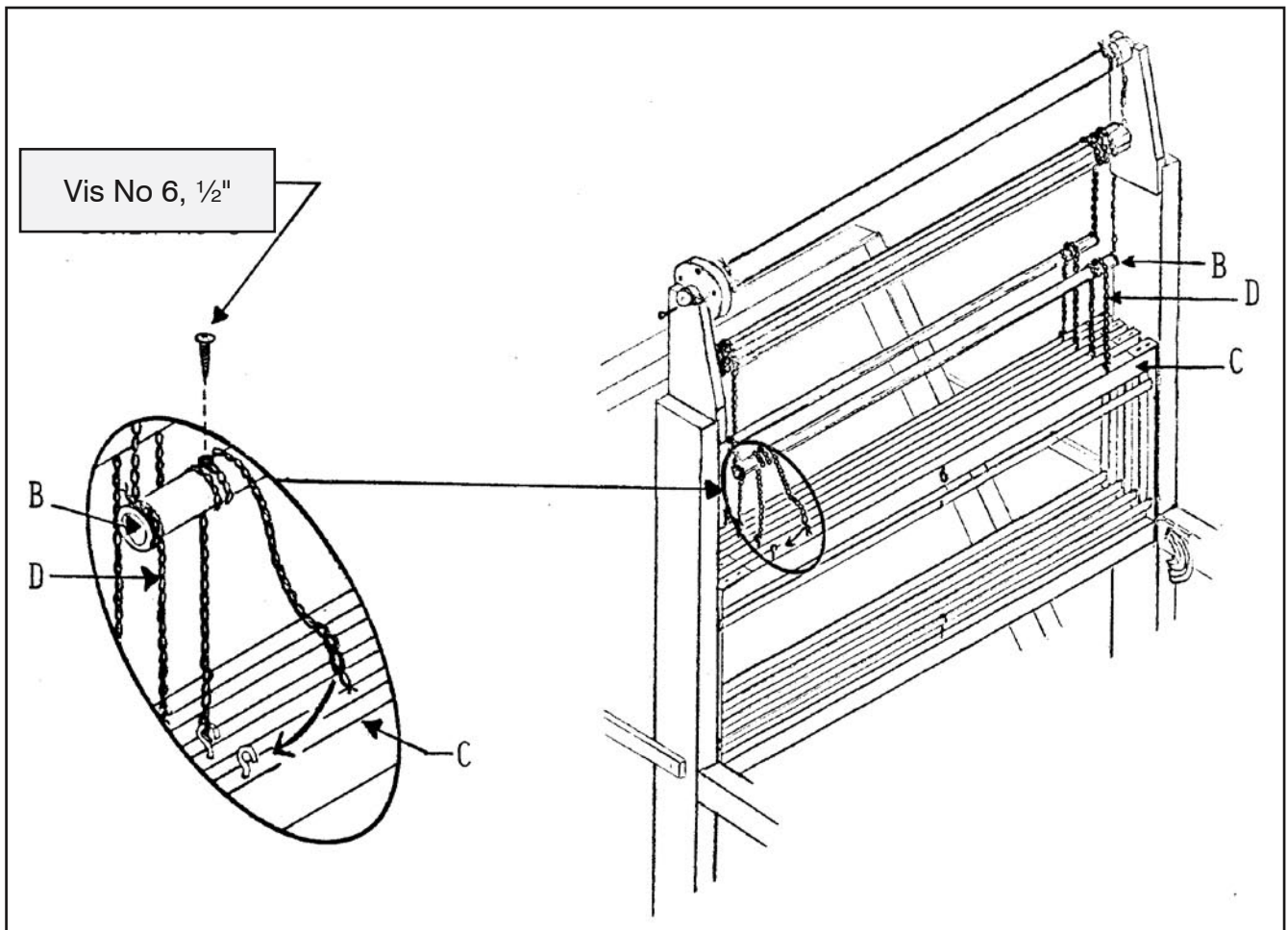

Fasten four No 6 , 1/2" round-headed screws into the holes on the top of the small rollers. Do not fully tighten.

Locate the loop nearest the midpoint on each of the four 20" loop cords and place under the head of the screws in the small rollers.

Cords D must be passed around the small rollers B once. Select the second to last loop at each end of these cords and slip onto the hooks of the harness frames.

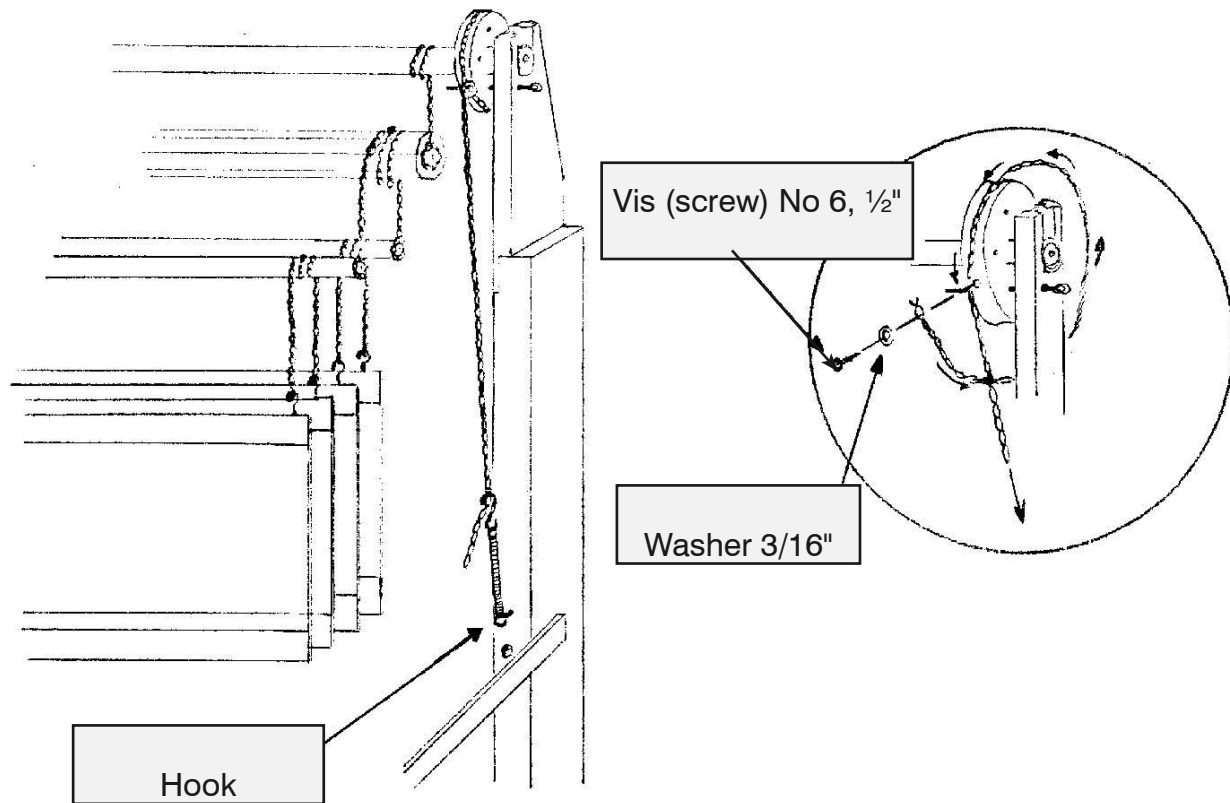

Stand behind the loom, facing the shed regulator.

Using one 1/2" round-headed screw No 6 and one 3/16" flat washer, attach one end of the 45" loop cord to the pulley of the shed regulator. Pass the cord once around the pulley in a counter-clockwise direction.

Slip an "S" hook onto one end of the spring (the new spring is shorter than the one in the video).

Affix a hook into the hole located at the back of the left central post and attach the other end of the spring to it.

Attach the "S" hook on the upper end of the spring to the loop cord of the shed regulator, adjusting the height of the harness frames such that the heddles are a little higher than the center of the reed (the loom has to be fully open).

See WARP AND WEAVE.

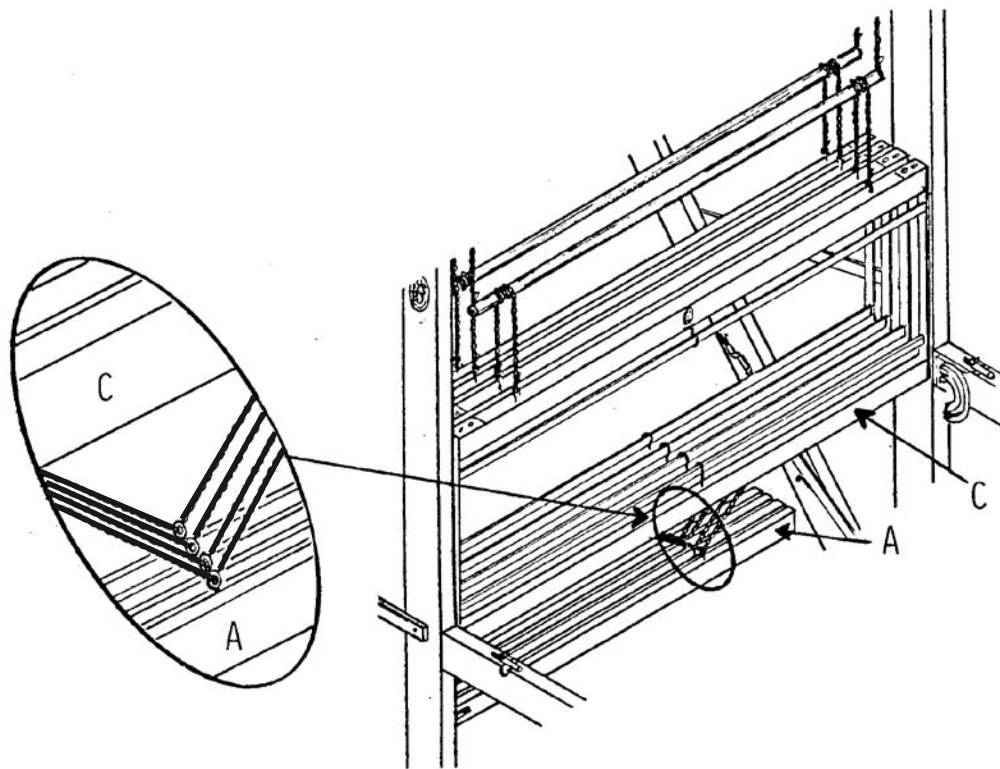

NOTE: Don't forget to string the heddles prior to attaching the shaft frames to the lams.

Connect shaft frames C to lams A.

Your loom is now adjusted for a counter- balanced weave. If you wish to treadle one harness against three, you must engage the shed regulator by removing the metal pin from the pulley, and readjusting the tension of the spring (by inserting the "S" hook in different loop) to obtain the best possible shed.

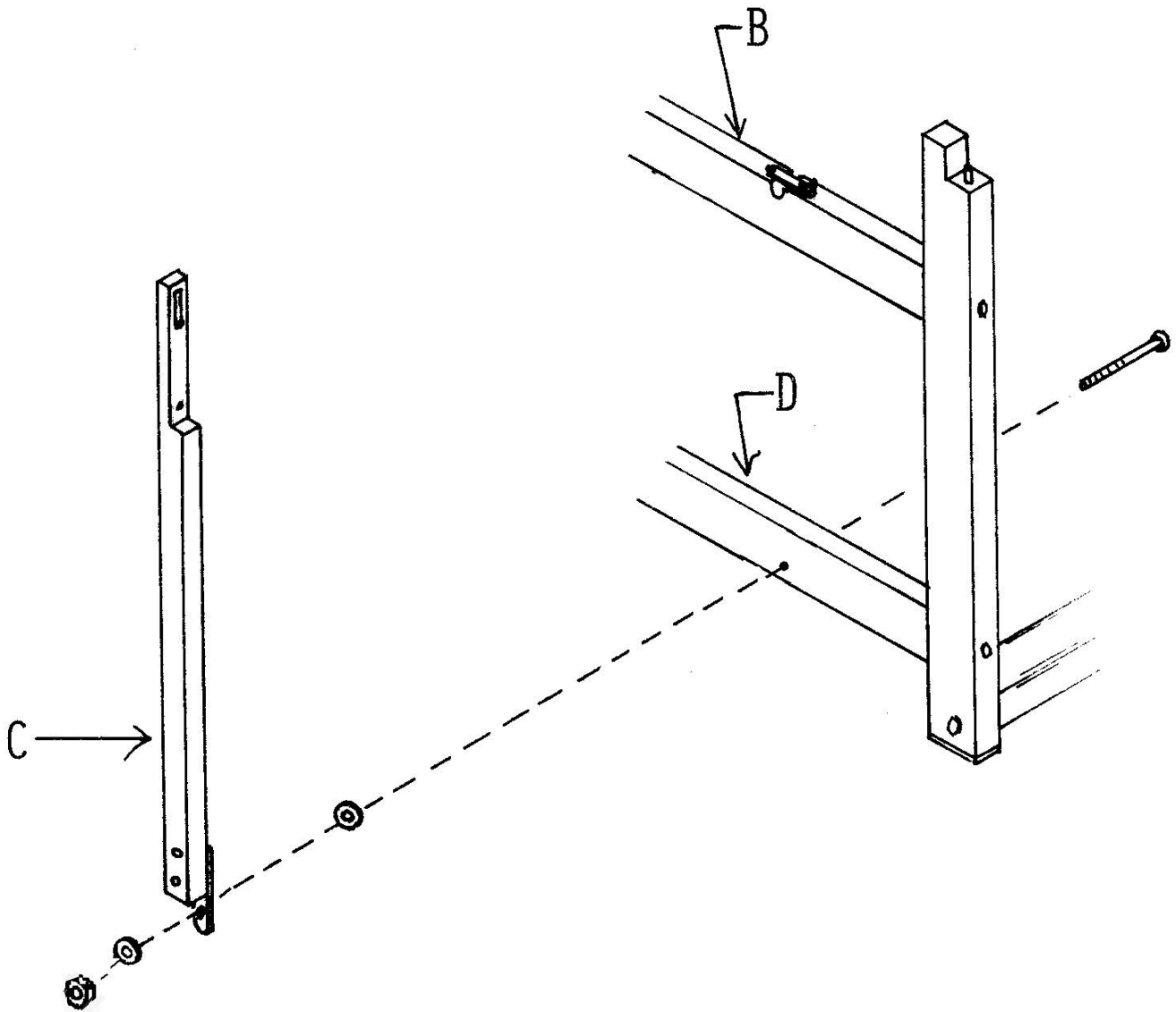

Affix batten swords C to the lateral cross-members D. Insert the two 5/16 x 2 1/4" carriage bolts to the low cross member D.
Hammer those carriage bolts inside the hole so they will lock while you will screw the auto lock nuts.

You also need four steel washers and two 5/16" autolock nuts. Place a steel washer between the **autolock exagon nut** and the sword and another one between the sword and the cross-member.

Do not tighten the bolts too much as the batten must move easily.

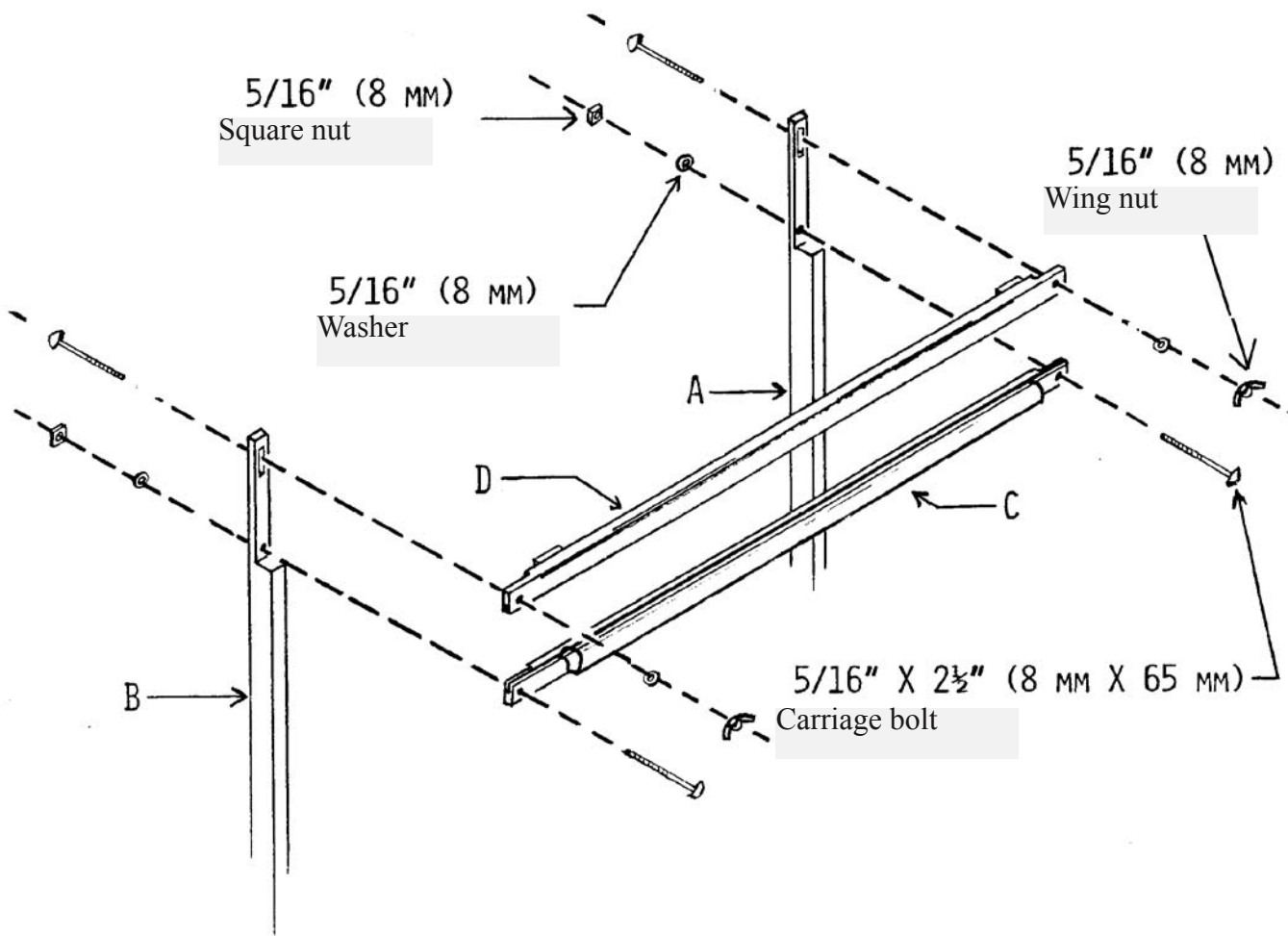

Affix batten sley A (with shuttle race) to the bottom of the batten sword grooves C. Insert a 5/16" x 2 1/2" carriage bolt into both ends of batten sley A, then into the hole at the bottom of the sword groove C. (The groove of sley A must be on the upper side.) Complete with washers and square nuts.

Affix batten handtree B to the slots on top of the sword grooves C. Insert a 5/16" x 2 1/2" carriage bolt into both slots of the batten sword C, then to the batten handtree. (The groove of the handtree A must be on the underside.) Complete with washers and wings nuts.

WARP BEAM INSTALLATION

Disconect brake circle A from the turnbuckle.
Open both latches of the back posts.
Unhook the turnbuckle 5874-0000 from the brake circle
DO NOT UNROLL THE BRAKE CIRCLE.

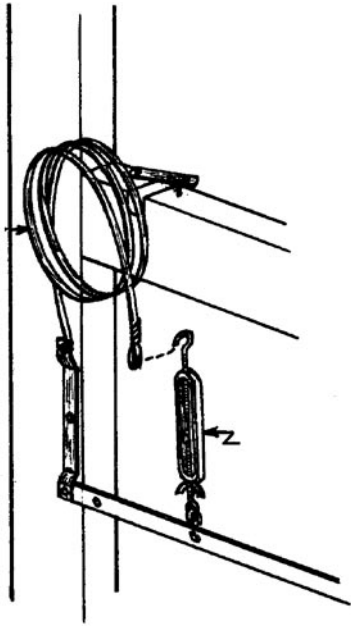

In order to improve the rotation of the warp beam, special bushings are supplied. Make sure to leave them in place when installing the warp beam on the loom.

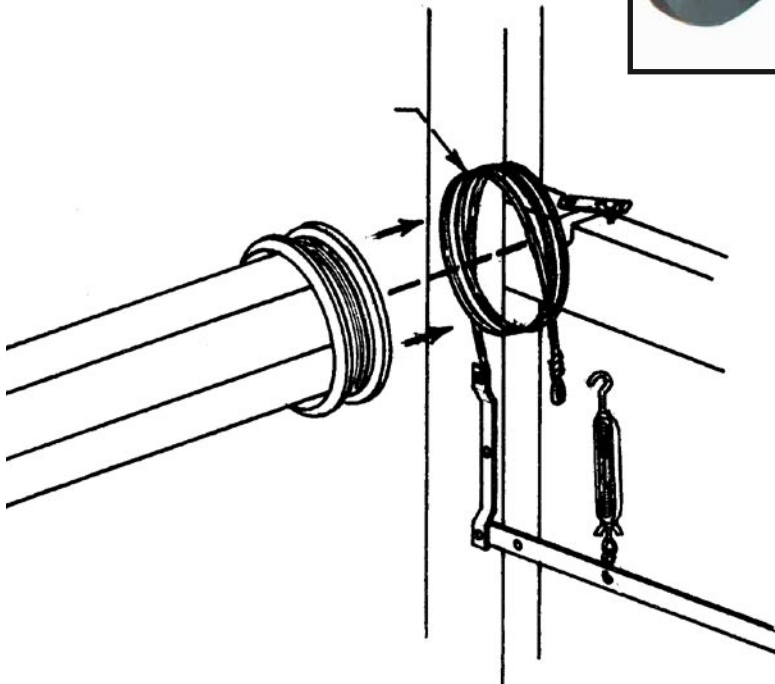

Insert the brake drum B into the wire brake circle A.
Then, install the ends of the groove of the back post. Close and secure both latches.

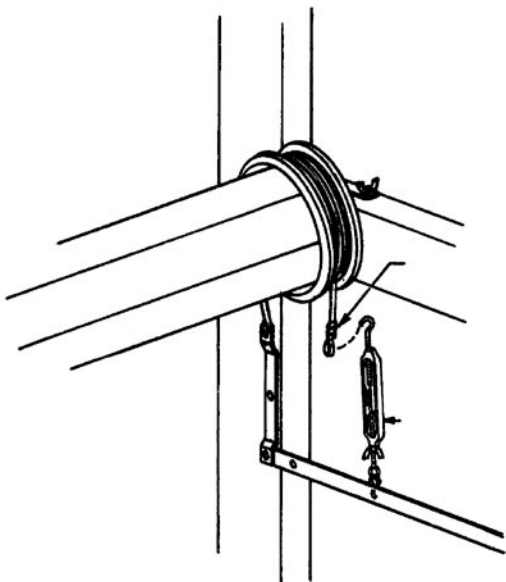

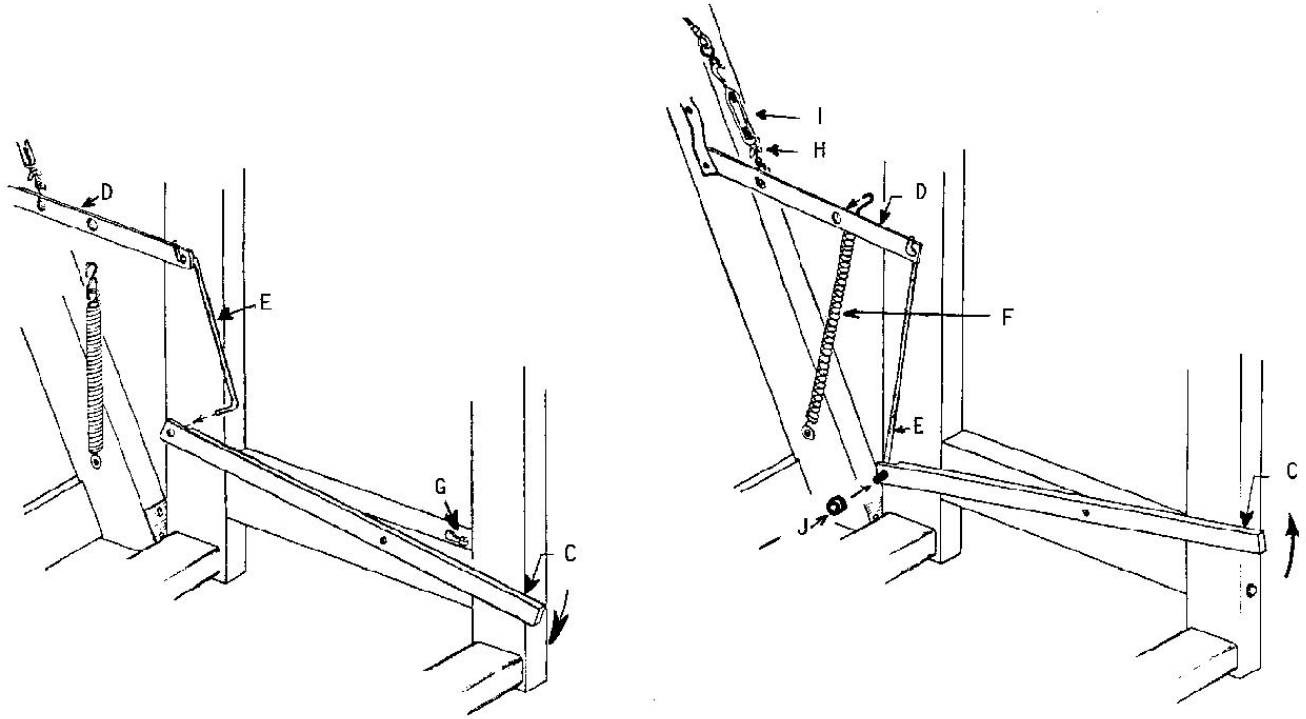

If needed, make the brake treadle connection .
 Push down and lock the brake treadle.

If the loom is equipped with a sectional warp beam,
 the rake-like pieces must be affixed to the warp beam.
 If not, affix the apron to the warp beam with the tacks
 supplied with the loom.

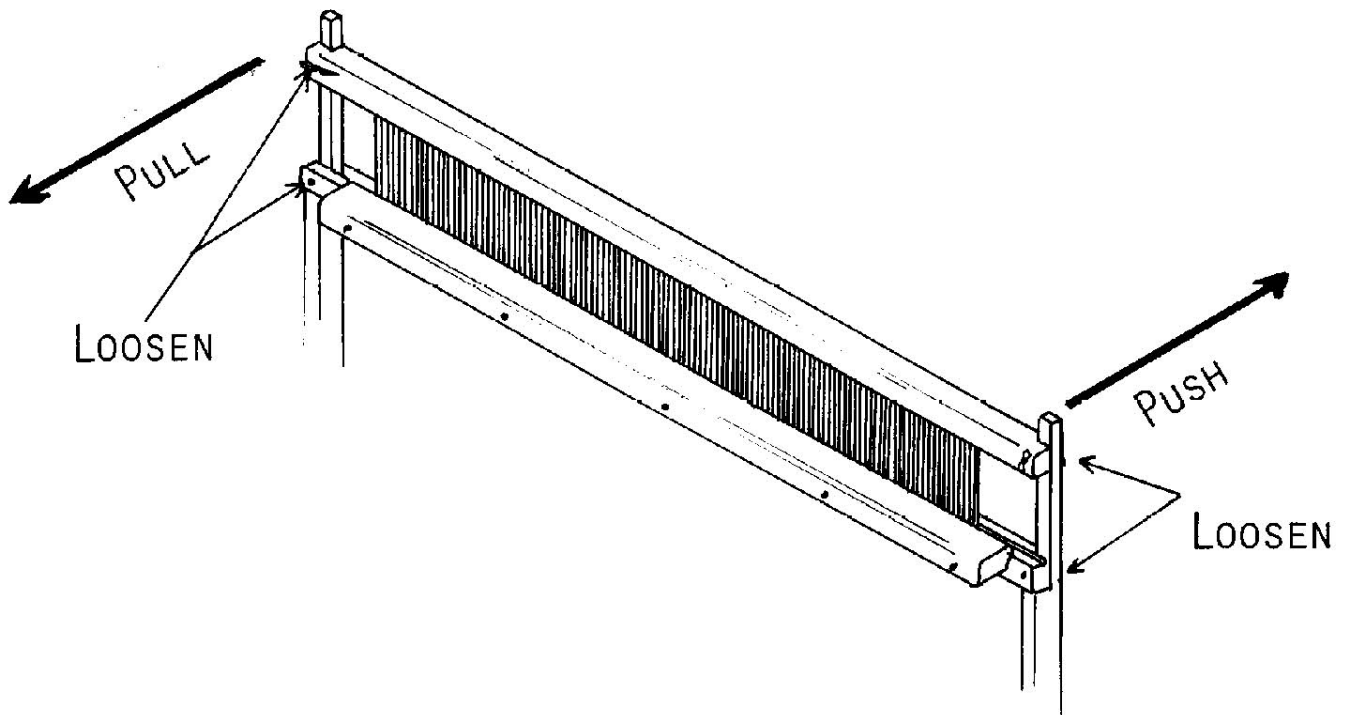
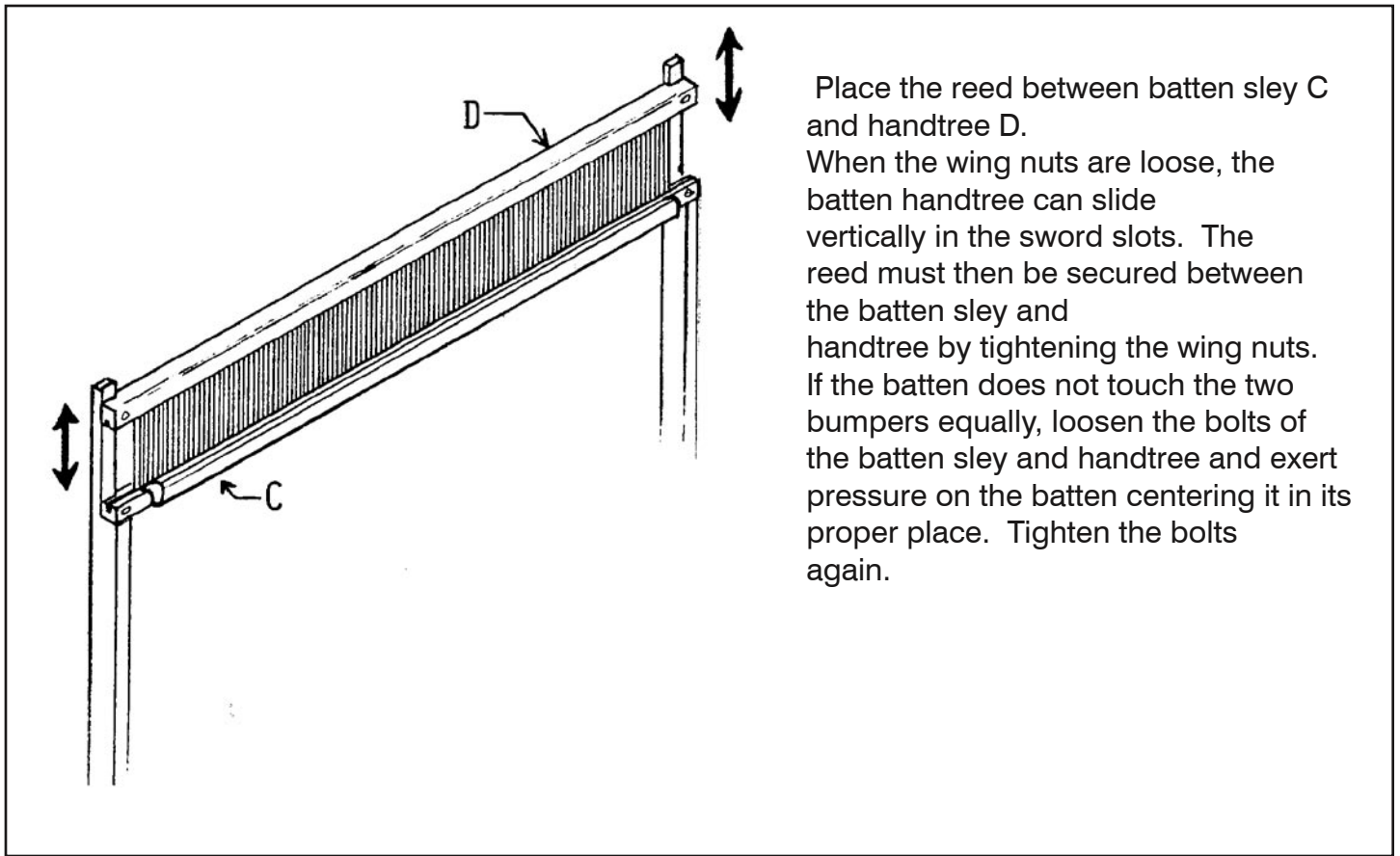

If the batten does not touch the two bumper equally, loosen the bolts of the batten sley and batten handtree and exert pressure on the batten centering it in its proper place. Tighten the bolts again while keeping pressure in the batten straight.

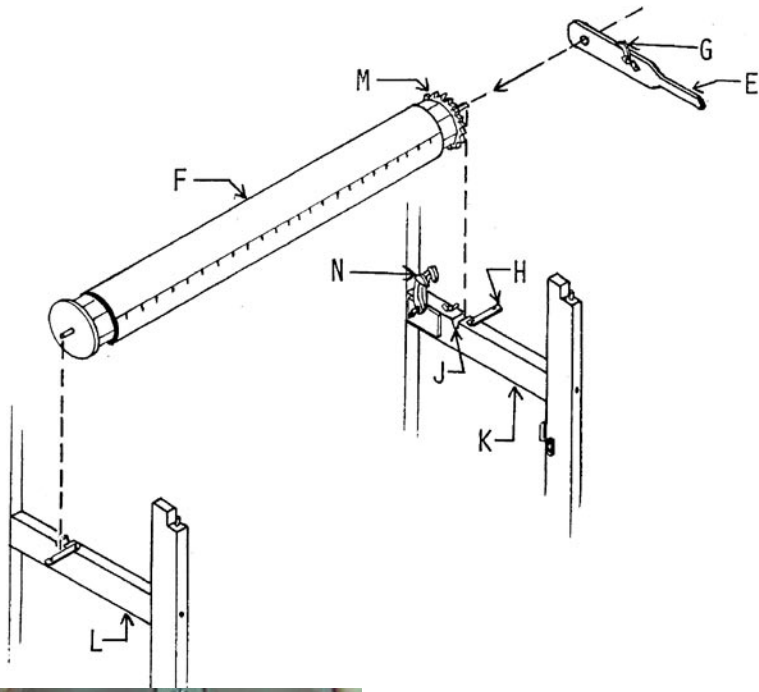

Install take-up motion handle E on the axle end of cloth beam F (on the same side as the ratchet gear). Ratchet pawl G of the take-up motion handle must be lifted up.

Open beam latches H and place the beam ends in the slots J of the upper side cross- members K and L.

Note: Ratchet gear M must be on the right-hand side and ratchet pawls N must be lifted up.

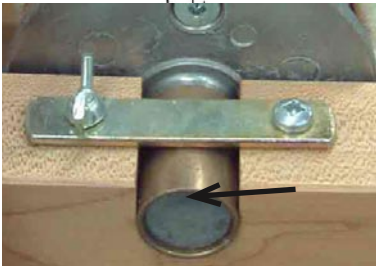

In order to improve the rotation of the cloth beam, special bushings are supplied. Make sure to leave them in place when installing the cloth beam on the loom.

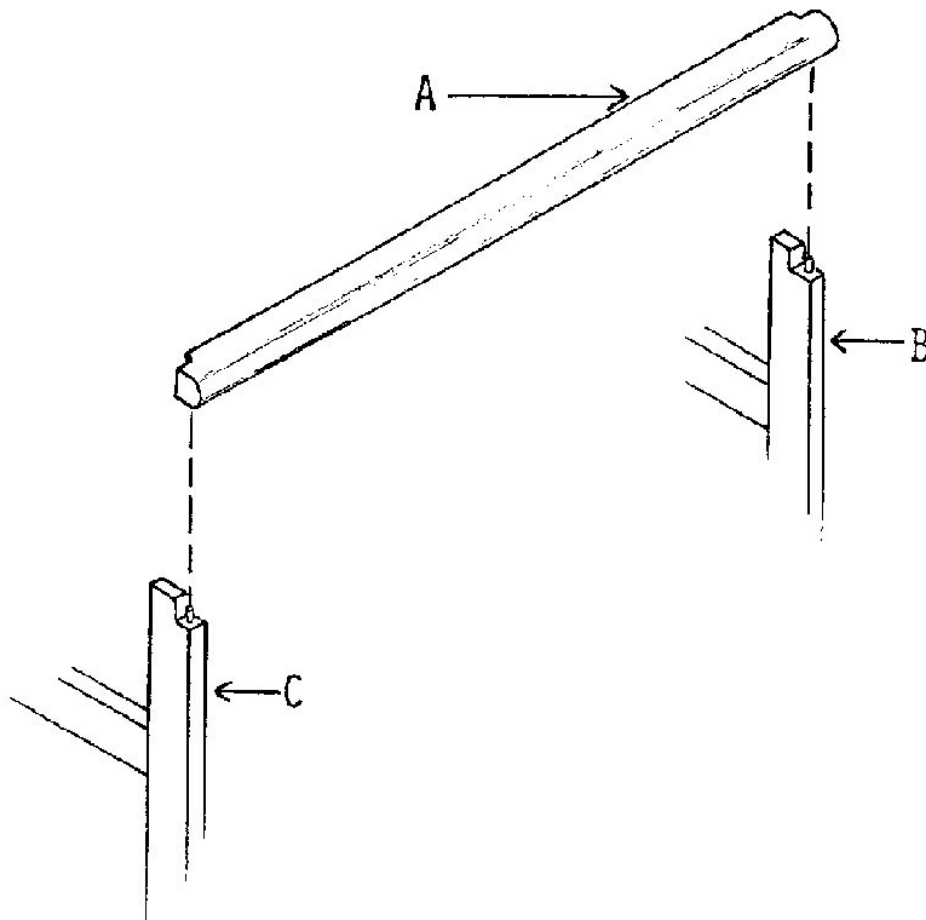

Affix one of the breast beams A on the top of the front posts B and C.

Affix the other breast beam on top of the back posts.

NOTE: To avoid splitting the front posts, slightly insert the breast beam onto the metal pin. Be sure that it is in the right position before inserting it completely.

FOLDING LOOM AND BEAMING:

Release the brake by depressing treadle C and by locking it down with catch G. Release the 4 metal hooks and fold the back of the loom.

WEAVING:

To advance the warp, depress brake treadle C and turn cloth beam H at the same time. Then release brake treadle C and advance the cloth beam until the next notch in the ratchet gear is reached.

If this is too much tension, gently depress the brake treadle until the desired tension is obtained.

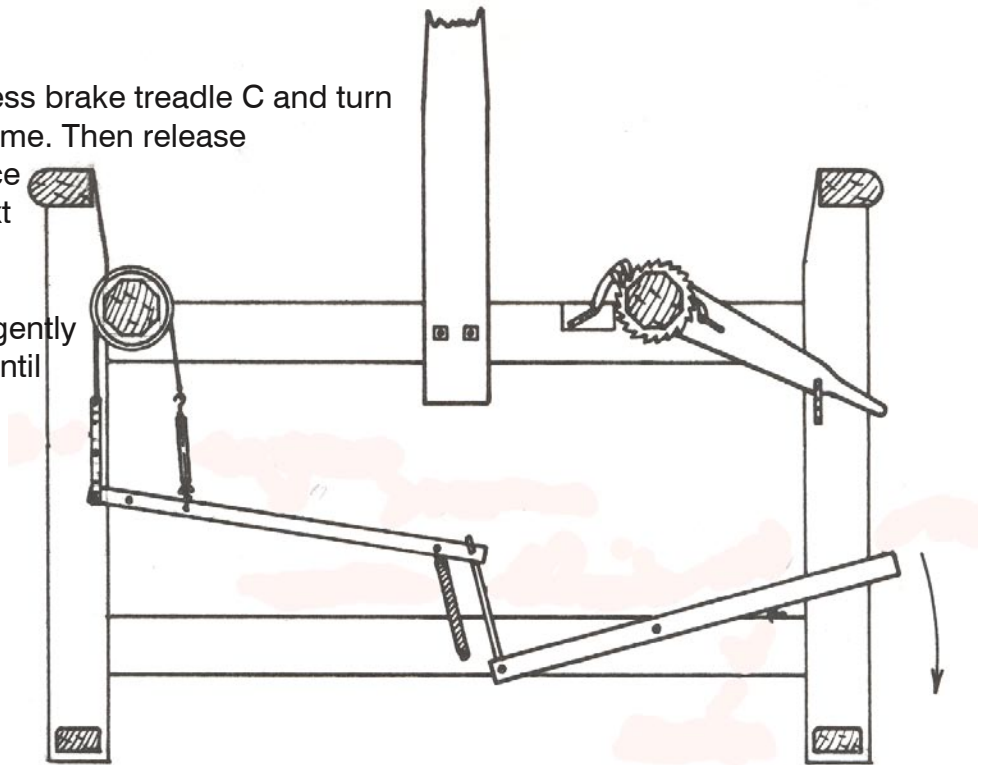

Note while winding a warp with a Leclerc Friction Brake

To maintain proper adjustment and operation of your Friction Brake, it is recommended that the Brake be disengaged while winding the Warp.

On those looms designed with a Treadle or Lever Lock, the Brake should be locked open when winding.

MORE INFORMATION:

See "WARP AND WEAVE"

Install the Warp beam advance control system.

This system will eliminate excessive warp yarn advance when releasing the brake system at cloth take-up.

This friction system is adjustable and **have to be released when winding the warp on.**

Just screw the handle in to increase the friction or unscrew it to release.

Affix it to the back left side of the loom using 2 round head screws no 12 - 1" to the pre-drill holes.

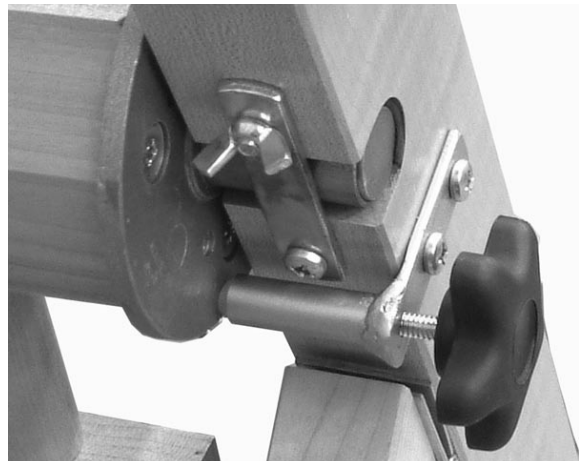

FIRST TIE-UP

Refer to the book "Warp & Weave"
supplied with the loom.



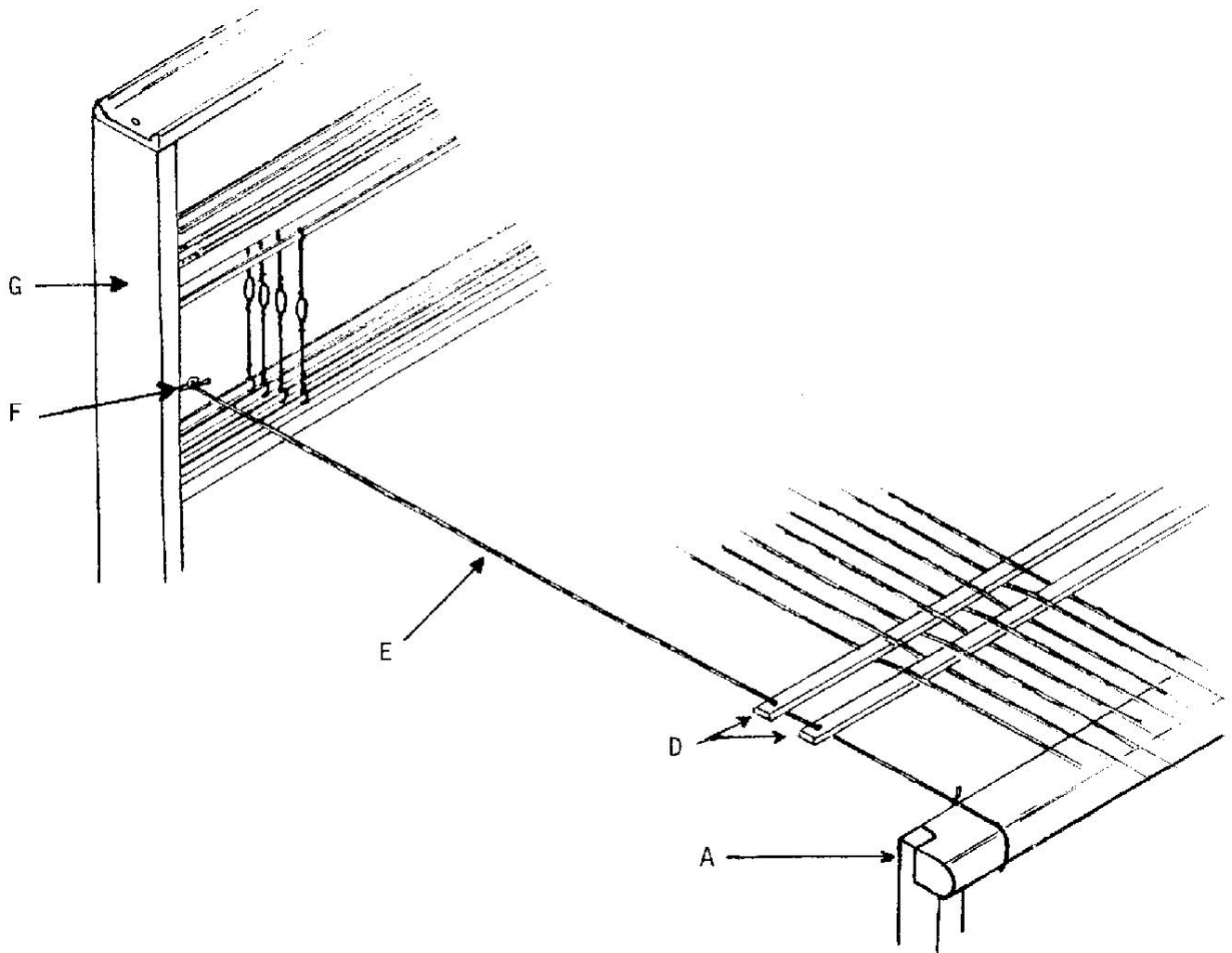

Affix screw eyes F to the holes inside middle posts G.

Pass a string C through the holes at each side of the lease sticks D and tie them to the screw eyes and to the thread beam A. The lease sticks will be held at the right height and distance for easy threading.

A) & B) When the shed regulator is not needed, (even shed) lock the pulleys with the metal pin. To have a nice shed, lock the pin so the warp threads pass app. at the center of the reed when the shed is close.

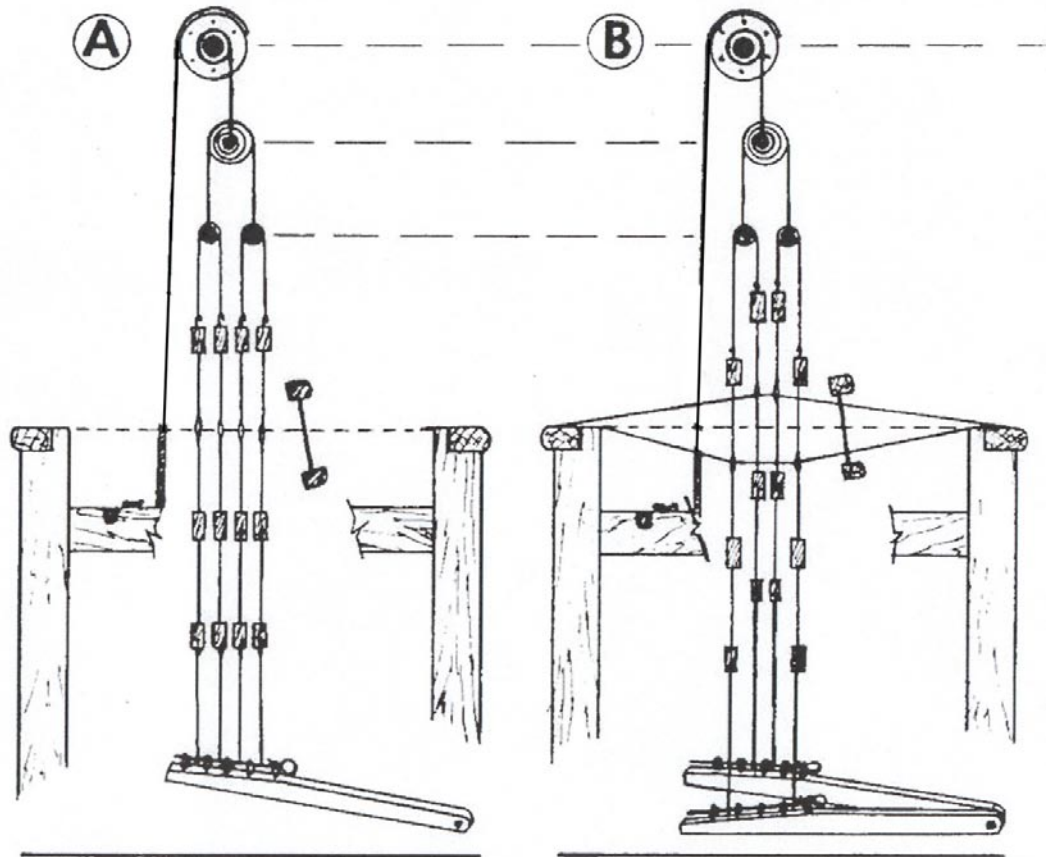

C) & D) Remove the metal pin to weave uneven shed or to weave with very high tension on the warp. Adjust the length of the loop cord so the shed is maximum with all tie-ups of the pattern.

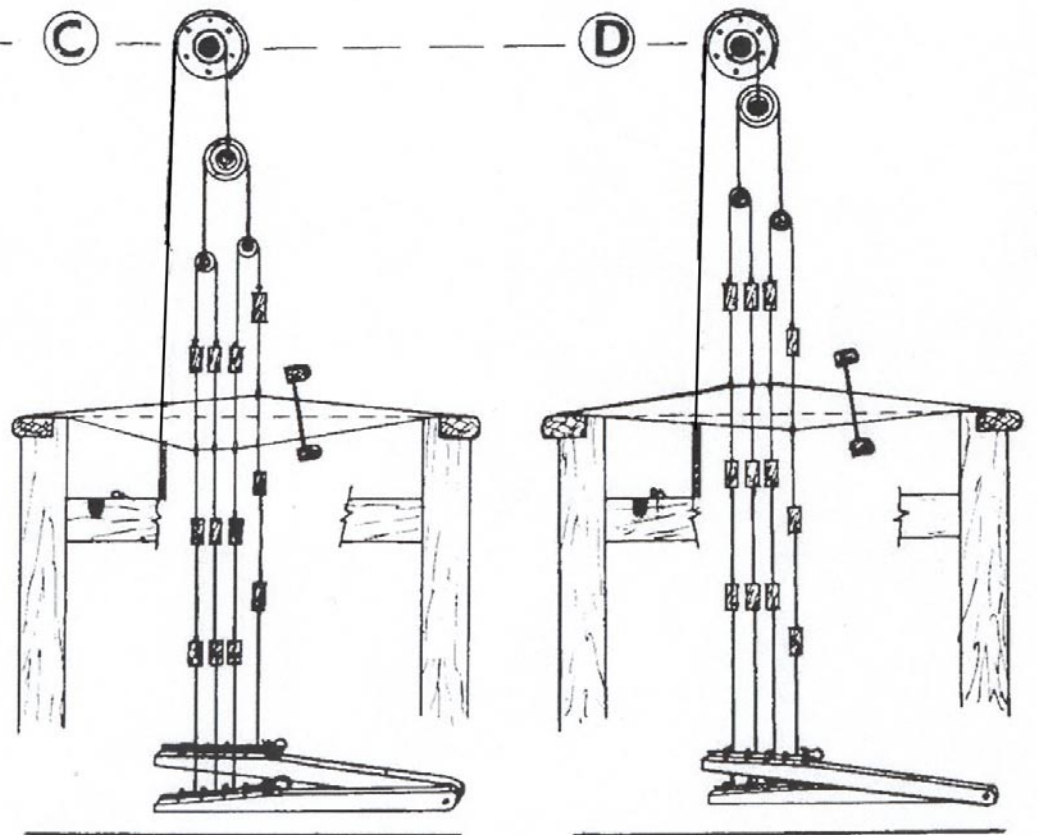

If the loom is equipped with a sectional warp beam, affix the rake-like pieces (following the instructions supplied with the sectional warp beam) and do the following instructions on the cloth beam only.

If the loom is not equipped with a sectional warp beam, affix the apron to the warp beam with tacks and do the following procedures on the warp and cloth beams.

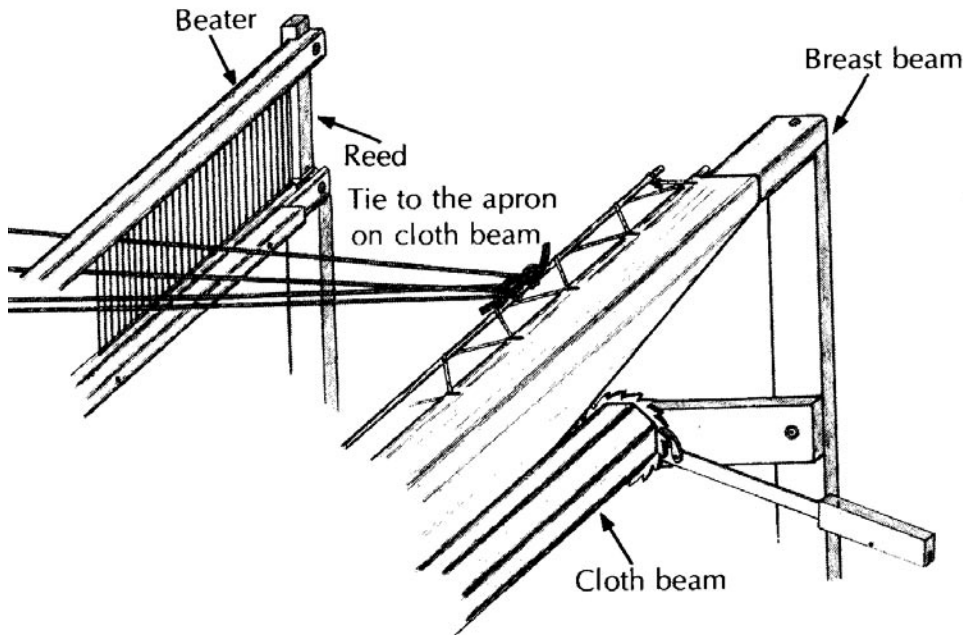

Insert a warp rod into the apron border.

For 27", 36" and 45" loom
(70cm, 90cm and 115cm)

For 60" loom
(150cm)

Cut the 5 yard (4.5m) cord in half.
Use one half of the cord to lace the apron warp rod to a second warp rod. This second warp rod will be used to attach warp threads.

Use a 5 yard (4.5m) cord to lace the apron warp rod to a second warp rod. This second warp rod will be used to attach warp threads.

**We at Leclerc encourage Weaver feedback on
this and all our products. Please
send your comments to Leclerc Loom Co.
info@leclerclooms.com**

HAPPY WEAVING